

Owner's handbook

**3.0 CS
3.0 CSi**



i.e.

№ 12 16/4/74

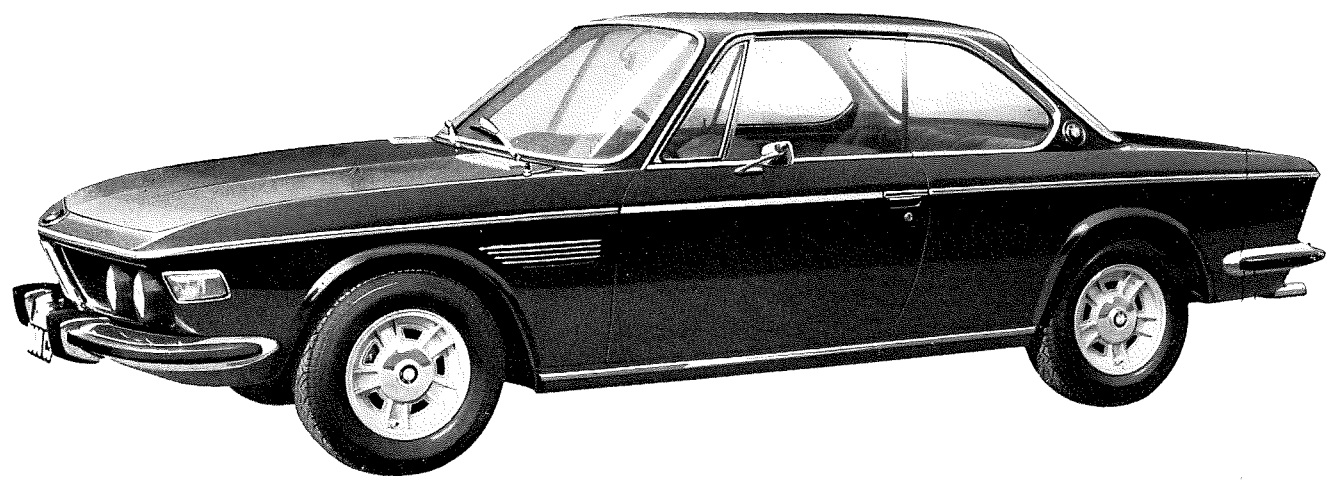

e
e
t
e
e
e
E

We reserve the right to modify designs,
equipment and fittings in the interests
of continuing technical development.
Dimensions, weights and performance data
are quoted to generally accepted tolerances.
Errors and omissions excepted.

Dear BMW owner,

In congratulating you on your new BMW, we trust you appreciate the qualities of the car you now own. The road-holding and performance of the car enable you to be courteous and careful in traffic, yet accelerate away from the crowd when conditions permit.

However, the power of your car only has real meaning if you handle it with confidence. Therefore, please take a little time to study the hand book, with its recommendations for trouble free driving pleasure.

Sincerely yours,
BAYERISCHE MOTOREN WERKE
Aktiengesellschaft

Contents

Before you start — all you need to know	6–27	Engine compartment lock and lighting, trip mileage recorder, fog lights, rear fog warning light, heated rear window, hazard warning flashers, electric window lifts, twin-tone electric horns	12–15	Engine oil consumption, driving hints, foreign travel, checking oil level	38– 39
Maker's plate, chassis and engine numbers	26	Combined instrument	15	Hydraulic power steering, automatic cooling fan coupling, electric auxiliary fan, limited-slip differential	40
Keys, locks, opening and closing doors	6– 7	Selector lever indicator lights, coolant thermometer, fuel gauge, fuel filler, rear lights, luggage compartment lighting, rear fog warning light, front seats, safety belts, handbrake	16–18	Winter precautions	41– 42
Controls and instruments	8– 9	Gearbox gate pattern, reversing lights, exterior and interior rear view mirrors, sun visors, interior light	19	What to do, if	43– 53
Levers and switches	8– 9	Glove box, clock, cigar lighter	20	Changing a wheel	43
Screenwipers, screenwasher	12	Ashtrays, car radio	22	Minor faults	44– 46
		Centre armrest, steel sliding roof	23	Fuses	48
		Heating and ventilation	24–25	Bulb-changing	49– 51
		Automatic transmission	26–27	Headlight beam setting	51– 53
		Starting off	28–29	Care and maintenance	54– 77
		Starting the engine	28	Washing and cleaning the car	54– 56
		Starting and stopping	29	Service	58– 60
		Electronic fuel injection system	29–33	Description of maintenance routines	61– 75
		Running-in — but how?	34–35	Carburettors	76
		Running-in rules, maximum permitted continuous and top speeds	34– 35	Idling adjustment of fuel injection system	77
		On your way	36– 42	Specifications	80– 97
		Fuel grades, fuel consumption economy	36	Lubrication chart	98– 99
				Electrical wiring diagrams	100–105
				Oil grades for automatic transmission and hydraulic power steering	106–107
				BMW Spare Parts Service	108–109
				Item reference	110–112
				At a glance	113
				Tyre pressures, spark plugs, contact breaker points gap, ignition timing, valve clearances, V-belts, filling capacities	



Many features need no
maintenance . . .

. . . on your BMW Coupé.
Including the famous advanced
design safety-first chassis, with its
ability to withstand far more power
than even this lively 6-cylinder
engine can develop.

However: it will repay you to
observe the BMW maintenance
instructions.
Follow them exactly. That is the best
way to preserve the maximum value
of your car.

Before you start — what you need to know

The identity of your car can be established by comparing the registration documents with the **maker's plate, chassis and engine numbers**.

The model reference, chassis number and other important data are entered on the documents, and should be compared with the numbers stamped on the car's bodywork. These numbers and data are essential for all enquiries, inspection work, claims for parts, and similar. You should therefore familiarize yourself with their locations on the car.

Maker's plate: In the engine compartment, on the right hand side looking forward. **Fig. 1**

Chassis number: In the engine compartment, on the right hand side of the heater bulkhead looking forward. **Fig. 1**

Engine number: On the engine block at the rear left hand side, looking forward, above the starter motor. **Fig. 2**

You have received two pairs of keys with your new BMW. It is best to deposit the second pair in a safe place so that they can be obtained without difficulty if the first pair is lost.

Please make a note of the key numbers immediately, as these numbers are very important should you need new keys. All of the BMW service stations will be glad to assist you in procuring new keys whenever necessary. **Fig. 3**

1

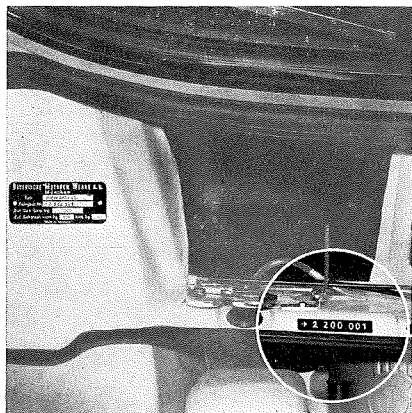

2

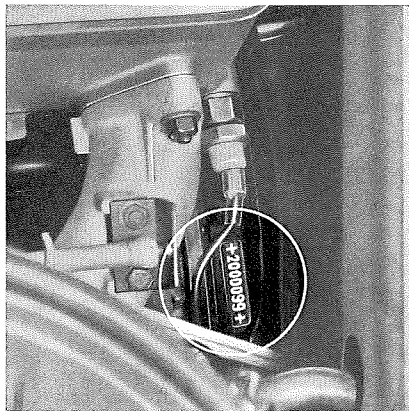

3

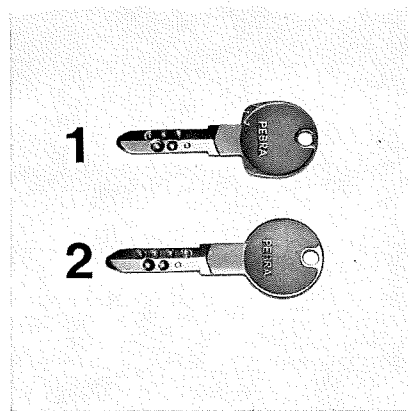

Key 1, **Fig. 3**, fits both door locks and the ignition/starter switch, which is combined with the steering lock. To open a door, insert the key and turn forwards; to lock a door, turn the key towards the rear of the car. Master key 2, **Fig. 3**, fits all the locks on your BMW. This combination of keys and locks enables you to leave the car in a garage or at a repair workshop with your luggage and valuables protected against theft.

To open the door from the outside, lift the flap-type door handle. **Fig. 4**

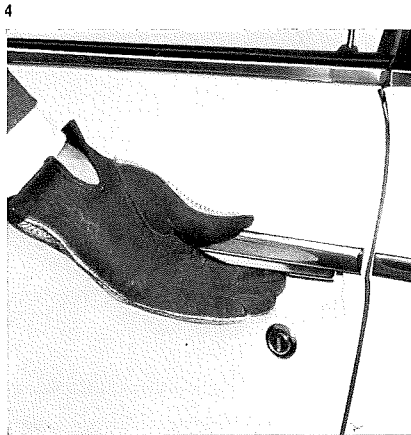

To lock a door from the inside, press the safety button down; to unlock and open from the inside, pull up the handle beneath the armrest. **Fig. 5**

If the door is already open, the safety button cannot be pressed down. This ensures that you cannot accidentally lock yourself out of the car.

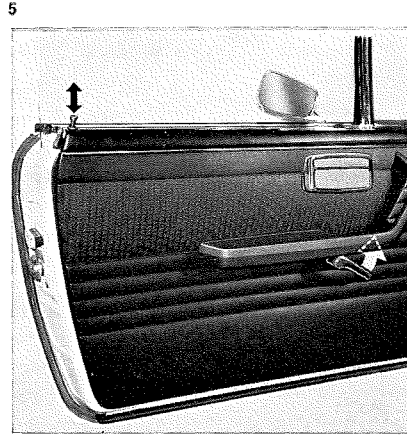

The **swivelling vent windows** in the front doors are closed or opened by turning the large knob immediately beneath. **Fig. 6**

When leaving the car, remember to close the vent windows by turning the knob fully back against its stop, so that the danger of theft is avoided.

Key 2 is required to lock and unlock the **luggage compartment**.

Please do not forget to lock the luggage compartment after closing.

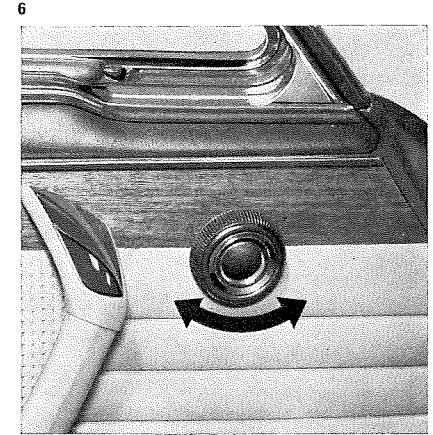

Controls and instruments

Note: Figures in square brackets [] indicate pages on which items are described in detail.

1. Headlight dip and flasher lever [10]
2. Combined instrument with fuel gauge [15]
Coolant thermometer [15]
and telltale warning lamps [15] for:
Oil pressure, and if required, turn
telltale for trailer (O) — orange
Battery charge (L) — red
Fuel reserve (T) — white
Headlight main beam (F) — blue
3. Horn button [15]
4. Speedometer with mileage and trip
recorders and turn indicator telltale
(green) [11]
5. Selector lever position indicator (on
Automatic models only) [16]
Position P (white)
Position R (red)
Position 0 (white)
Position A (green)
Position 2 (green)
Position 1 (green)
6. Steering lock and ignition/starter switch [10]
7. Switch for heated rear window [14]
8. Revolution counter [34, 35]
and brake telltale (red) [18]
9. Switch for hazard warning flashers [14]
10. Clock [20]
11. Lever for turn indicators, parking
lights, screenwipers and screen-
washer [11]
12. Heater: main on-off lever [24]
13. Interior rear view mirror [19]
14. Heater: air distribution lever [24]
15. Heater: temperature selector lever [25]
16. Loudspeaker grille
17. Sun visor [19]
18. Head and side light switch (2-position), with instrument
and control lighting [10]
19. Stowage compartment with lid [12]
20. Trip recorder reset knob
21. Rear fog warning light switch [13]
22. Clutch pedal (not on Automatic models)
23. Brake pedal
24. Accelerator pedal [28]
25. Wiper speed preselector switch [11]
26. Switches for electric window lifts [14, 15]
27. Handbrake lever [18]
28. Cigar lighter with plug socket [20]
29. Gear shift lever [19]
Selector lever (on Automatic models) [26]
30. Ventilation: fresh air inlet grille [24, 25]
31. Stowage space
32. Ventilation: cold air supply lever [25]
33. Glove box [20]

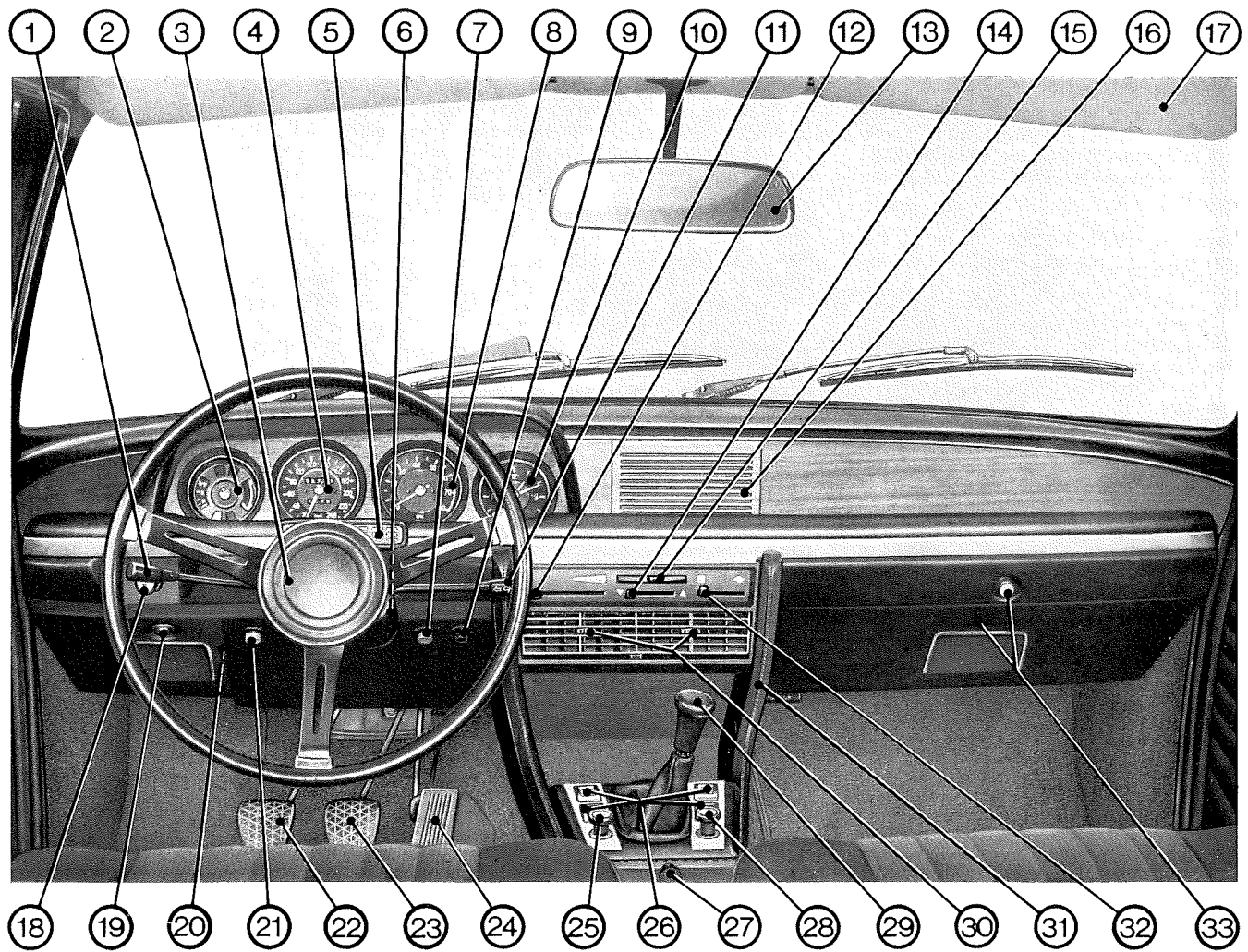

The **ignition/starter switch** on the right hand side of the steering column housing is combined with the steering lock. Insert key 1 at the «Halt» position of the lock only. **Fig. 7**

Turn the key to the right as far as the «0» position; you will hear the lock disengage, but you should turn the steering wheel slightly to assist if necessary. This unlocks the steering, and the radio and electric steel sliding roof (optional) can be operated. If the key is now turned further to the «Fahrt» (Drive) position, the ignition will be switched on, the battery charge (red) and oil pressure (orange) telltales will be illuminated, and the fuel gauge will register.

7

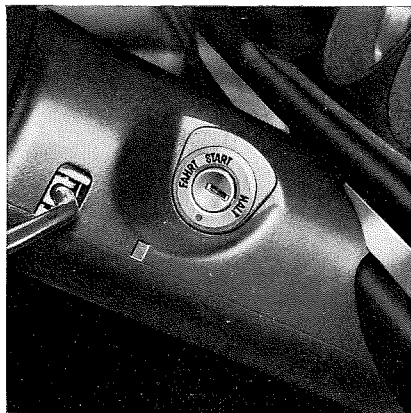

To lock the steering, turn the key back to the «Halt» position and withdraw. Move the steering wheel slightly if necessary until the steering lock is heard to engage. The ignition key can be removed in this position **only**.

Head and side light switch (2-position), **(Fig. 8):**

Position 1: side lights
Position 2: headlights

When the light switch is pulled out, the intensity of the **instrument and control lighting** can be varied by turning the knob.

8



The **headlight dip switch** on the left hand side of the steering column can be operated with the fingers of one hand without letting go of the steering wheel **(Fig. 9)**. When the headlight main beams (lever moved up) are in use, a blue telltale lamp is illuminated on the instrument panel. To **flash the headlights**, pull the lever towards the steering wheel rim. If the ignition key is turned to «0» or «Halt» while the headlights are on, they will go out and only the side lights will remain illuminated.

The **turn indicator lever** on the right hand side of the steering column beneath the steering wheel should be moved in a direction corresponding to the wheel to operate the appropriate turn indicators front and rear. **Fig. 10**

9

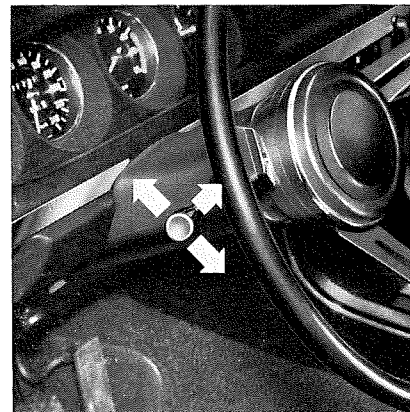

A regular ticking sound and illumination of the green telltale lamp in the speedometer indicate that the turn indicators are functioning correctly. **Fig. 11**

The oil pressure warning light also acts as a telltale for trailer turn indicators.

The indicators are automatically cancelled and the lever returned to its initial position when the vehicle is again proceeding in a straight line, but if the turn was only slight it may be necessary to cancel the lever by hand.

If the flashing indicators are to be operated for a short period only (e. g. changing lanes, overtaking, starting) press the turn indicator lever only slightly from its original position in the direction desired, without letting it engage. As

soon as you let it go it will return to its original position without the steering wheel being turned.

The **parking lights** on the right or left of the vehicle are switched on by moving the turn indicator lever up or down after locking the steering.

Lever up: left hand front and rear parking lights

Lever down: right hand front and rear parking lights

The **wipers** are switched on and off by pushing the turn indicator lever in towards the steering column. **Fig. 10**

The **wiper speed preselector switch** can be used to select either interval operation of wipers or one of two wiping speeds.

Switch pushed in:
interval operation of wipers

Switch pulled out to first stop:
1st stage (normal speed)

Switch pulled right out:
2nd stage (fast) **Fig. 12**

When switched to interval operation, the wipers operate automatically at short intervals. In light rain or snow etc. this has the advantage that it is not necessary to continually switch the wipers on and off. Use the 2nd stage (fast) only in heavy rain or snow.

10

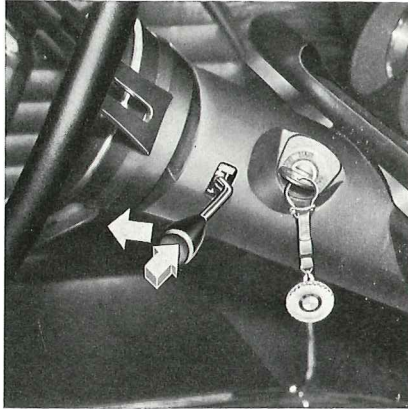

11

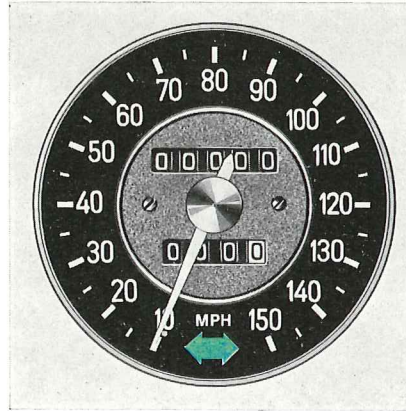

12

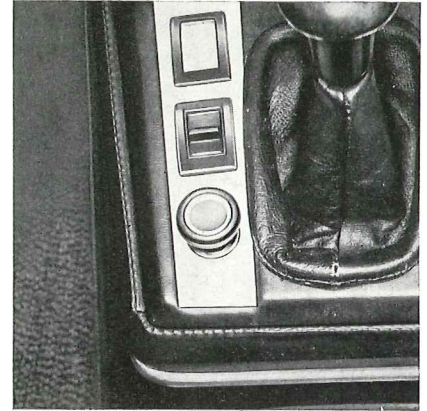

If the turn indicator lever on the right of the steering column is pulled up towards the wheel rim, the **automatic screenwasher** will be operated. The electric fluid pump and the wipers are switched on simultaneously. When the lever is released a delaying mechanism ensures that the wipers continue to operate until the glass is clean. **Fig. 10**

Warning: Do not use the automatic screenwasher when the fluid reservoir is empty.

Fig. 13 shows the two screewasher jets located on the engine compartment lid. If either of the water jets fails to strike the glass correctly (i. e. in the middle of the wiper area), the tube can be carefully bent by hand.

The **screenwasher fluid reservoir** (capacity approx. 2.5 litres/2.6 US quarts/4.4 Imp. pints) is in the engine compartment, on the right hand side. **Fig. 14**

The **engine compartment lid** opens forwards, and is released from inside the car by opening the **small stowage compartment** at the left hand side under the instrument panel (**Fig. 15**) and pushing forward the release lever located against the side panel. A spring-loaded mechanism ensures that the lid can be easily lifted from outside.

13

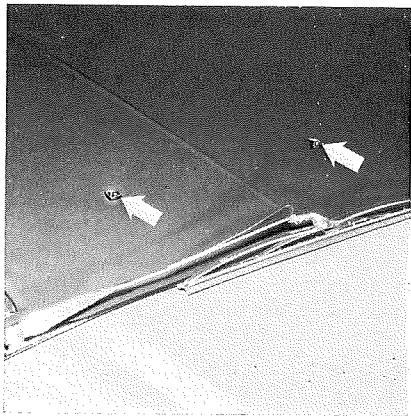

14

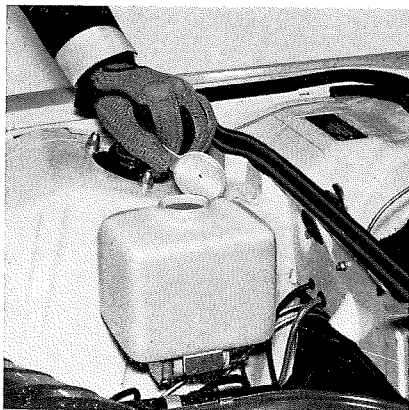

15

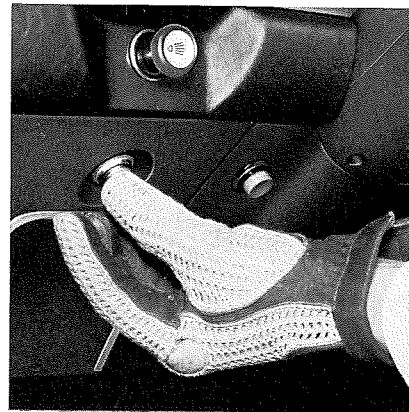

Warning: Before closing the engine compartment lid, the locking lever must be pushed forward. After closing the lid, pull the lever back to lock it, then close the stowage compartment. **Fig. 16**

The **engine compartment light** is illuminated when the lid of the engine compartment is opened, provided that the main light switch is pulled out.

The **trip mileage recorder** in the speedometer can be reset to zero by turning the knob inside the small stowage compartment (at the left hand side) clockwise. **Fig. 17**

The **push button switch** on the left of the steering column operates the **fog lights** (optional) and **rear fog warning light**, which is mounted to the right of the left hand rear light cluster. When these lights are illuminated, a telltale lamp glows inside the green switch knob. **Fig. 18**

16

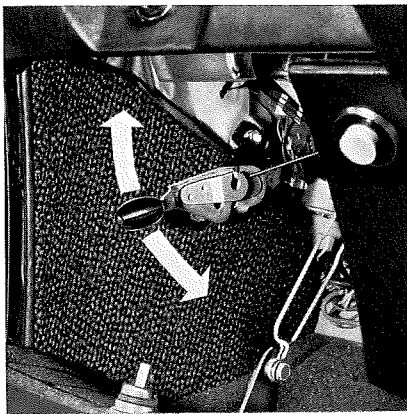

17

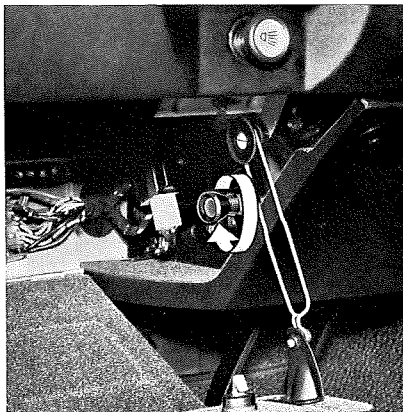

18

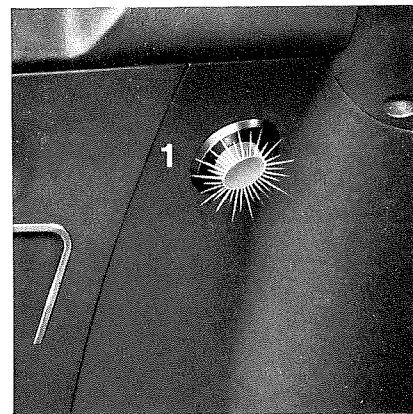

When the ignition is switched on, **switch 1, Fig. 19** can be pressed to supply current to a number of **electrical heating elements** in the **rear window**. The **yellow switch knob** lights up to indicate that the heated rear window is in use.

The **hazard warning flashers** are set in action by **push button switch 2, Fig. 19**, on the right of the steering column. They function whether or not the ignition is switched on. The **red switch knob** is illuminated at regular intervals to show that the hazard warning flashers are functioning correctly.

The electric window lifts for the side windows are operated by tumbler switches beside the gear shift lever.

Switch pushed forward = close window
Switch pushed backward = open window

1. Left hand door window (optional)
2. Left hand rear side window
3. Right hand door window (optional)
4. Right hand rear side window

Additional tumbler switches are fitted to the rear side armrests to operate the window immediately above. **Fig. 21**

19

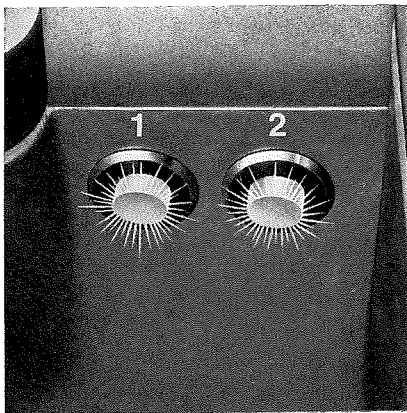

20

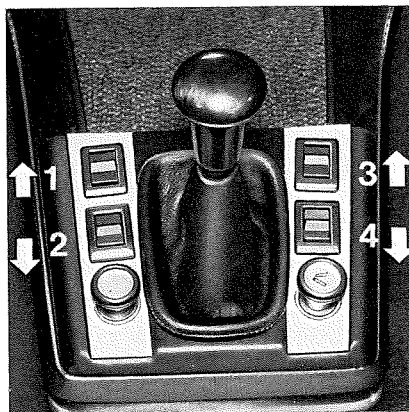

21



If an electric window lift should fail, the **windows** can be manually operated by means of the plastic toothed rack supplied with the toolkit.

Rear side windows:

Take off the cap in the side panel trim and make a hole in the partition behind. The pinion on the window lift drive mechanism can be turned in the desired direction by means of the toothed rack.

To open rear side window:

pull the rack towards the interior of the car.

To close rear side window:

push the rack in the opposite direction.

Fig. 22

22

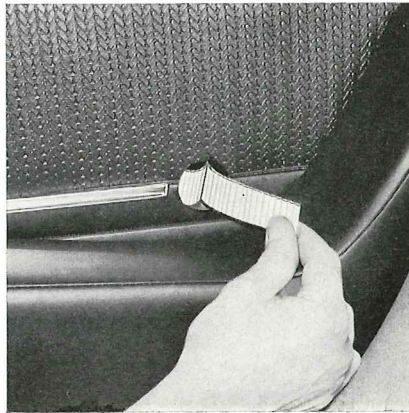

Proceed in a similar fashion if an electric door window lift should fail.

The electric twin-tone horns are sounded by means of the horn button in the centre of the steering wheel. **Fig. 23**

23



The **combined instrument** houses the fuel gauge, the colant thermometer and telltale warning lamps for:

Battery charge (red)
Oil pressure (orange), also acts as trailer turn indicator

Headlight main beam (blue)
Turn indicators (green)
Fuel level (white)
Brakes (red) **Fig. 24**

24

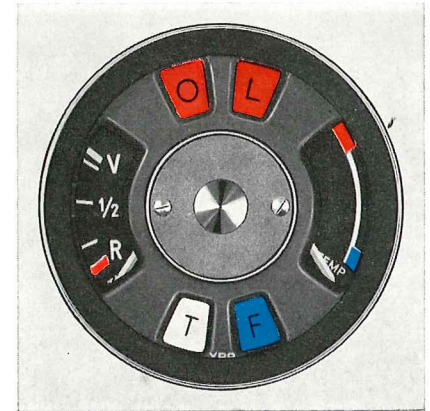

On the BMW 3.0 CS Automatic, the selector lever position indicating lights are mounted in a housing above the steering column:

- P (white)
- R (red)
- 0 (white)
- A (green)
- 2 (green)
- 1 (green)

Fig. 25

These lights are wired in an anti-glare circuit with reduced intensity when the car's side or headlights are in use. They remain alight as a precaution until the ignition key is turned to the «O» or «Halt» position, and the car's running lights are extinguished.

25

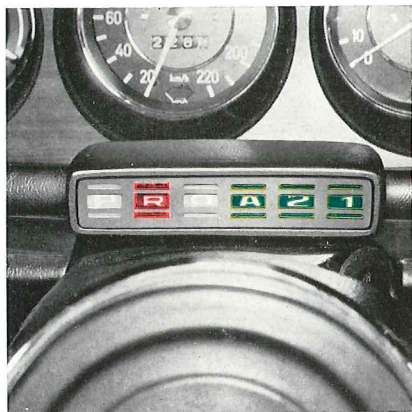

The **coolant thermometer** has three coloured zones:

Blue: engine too cold. Keep engine and road speeds moderate.

White: normal operating temperature

Red: engine too warm. It need cause no alarm if the needle reaches or enters the red zone for short periods when outside temperatures are very high or when the car is driven at very high speeds for a long time. If the needle tends to stay in the red zone, the matter should be investigated. See instructions on page 45.

When the ignition is switched on, the **fuel gauge** indicates the level of fuel in the tank. If the needle points to «Reserve» and the white telltale lamp lights up, you should add fuel immediately, although enough for about 30 miles (50 km), depending on the way the vehicle is driven, still remains in the tank.

As soon as the white telltale lamp begins to burn continuously, add fuel at once.

The **fuel filler** is located at the rear of the car, behind a flap. **Fig. 26**

A lockable fuel filler cap is available as an optional extra.

26

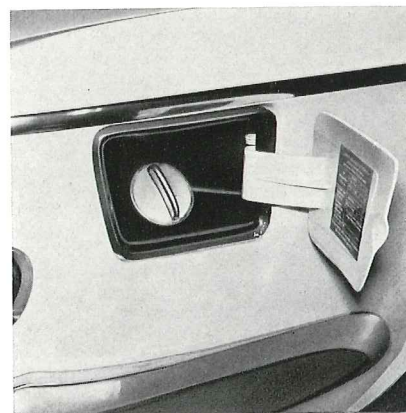

Fig. 27 shows the arrangement of the **rear light cluster** from the outside inwards:

- | | |
|--------------------|----------|
| 1. Turn indicator | (yellow) |
| 2. Rear light | (red) |
| 3. Reflector | (red) |
| 4. Stop light | (red) |
| 5. Reversing light | (white) |

The **luggage compartment light** is switched on automatically by a contact switch when the lid is opened.

A fog warning light is mounted in the rear body panel, at the left hand side next to the number plate. **Fig. 28**

To **adjust the front seats** in a fore-and aft direction, pull up the lever on the outside edge of the seat base and move the seat to the desired position. Then release the lever and ensure that the seat has locked into position correctly. **Fig. 29, 1**

The **front seat backs** can be adjusted by turning the handwheel on the outside of each seat support. **Fig. 29, 2**

27



28

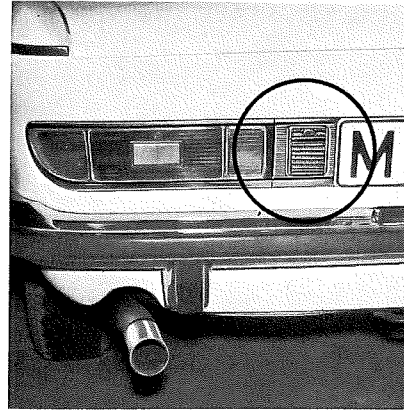

29

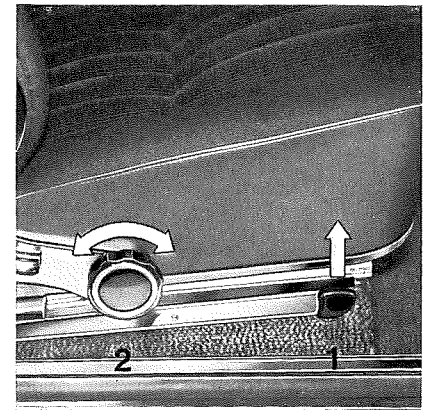

In addition, the front seat backs are provided with locking catches to prevent them from tipping forward accidentally. The lever on the seat back pivot must be pressed down before the seat back can be tipped forward. **Fig. 30**

Each of the two **headrests** can be adjusted vertically by pulling up or pushing in. Make sure that the headrest is not distorted and locks correctly into position. For reasons of safety the headrest should always be at head height, and never behind the neck.

Anchorage are provided on the bodywork for both front and rear seat **safety belts**. Your BMW dealer knows the location of these anchorages and will gladly supply and fit a set of safety belts on request.

The **handbrake** operates on the rear wheels. Pull the lever up to halt or secure the vehicle. To release the handbrake, pull the lever up slightly, press in the knob on the end of the lever and move downwards. **Fig. 31**

A useful hint: to apply the handbrake without undue noise, press in the knob while pulling up the lever.

When the handbrake is applied, a red «Brake» telltale is illuminated in the revolution counter. This is also a means of checking the functioning of the telltale at any time. **Fig. 32**

If the «Brake» telltale glows at any time during a journey, proceed as described on page 45.

30

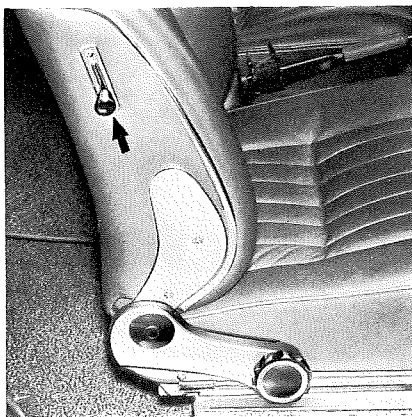

31



32

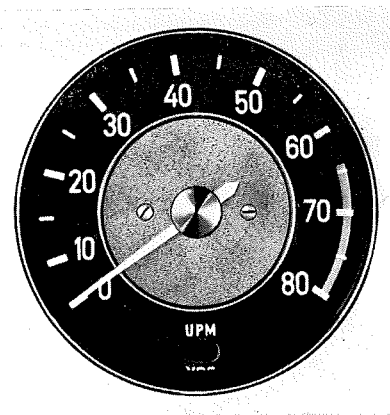

The gearbox **gate pattern** shows the position of the gear shift lever for each gear (for automatic transmission selector lever positions, see page 26). All forward gears are provided with synchromesh. **Fig. 33**

To engage reverse gear (only when vehicle is at a standstill) press the gear lever to the left until a slight resistance is overcome.

Both **reversing lights** are illuminated when the ignition is switched on and reverse gear engaged.

33

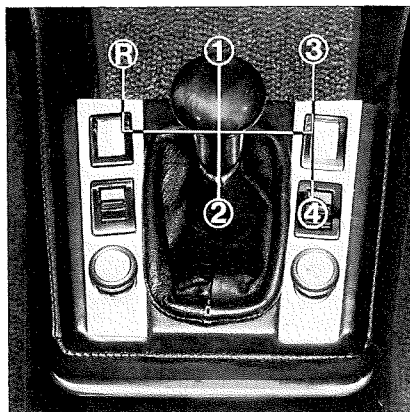

Do not forget to adjust the **exterior and interior rear view mirrors** to suit your normal driving position.

The **interior mirror** has a dipped anti-glare position, brought into use by pushing back the small lever at the base of the mirror's frame. **Fig. 34**

Both **sun visors** can be pivoted to one side to cover the side windows if the sun is in that direction. **Fig. 34**

34

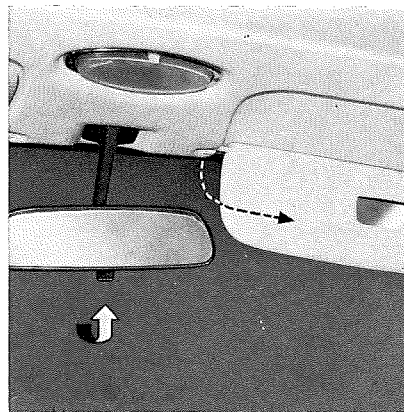

The switch on the **interior light** has three positions:

Position 1: light operates only when a door is opened (switches on door pillars)

Position 2: permanently off.

Position 3: permanently on.

Fig. 35

35

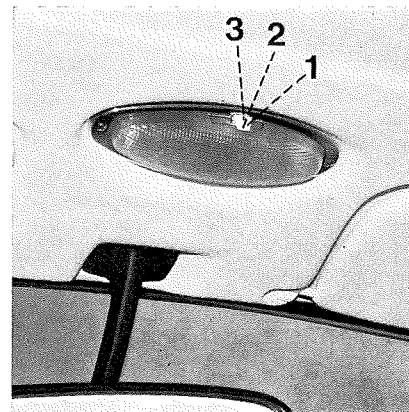

The glove box opens downwards when the push button immediately above is pressed. **Fig. 36**

When the lid is lowered, the glove box is automatically illuminated.

The hands of the **electric clock** can be adjusted by pressing and turning the knurled knob. **Fig. 37**

An adhesive tape strip on the back of the clock covers up the regulating screw, which is marked + (faster) and - (slower).

To use the **cigar lighter**, push in the knob. When the element has heated up the knob will spring back to its original position and can then be removed. **Fig. 38**

The cigar lighter **socket** can also be used to plug in an inspection lamp, electric razor or similar appliance, provided that the rating does not exceed 12 Volts, 200 Watts. Make sure that the socket is not damaged by attempting to insert unsuitable plugs.

36

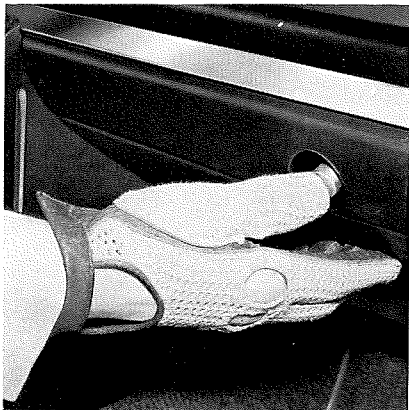

37

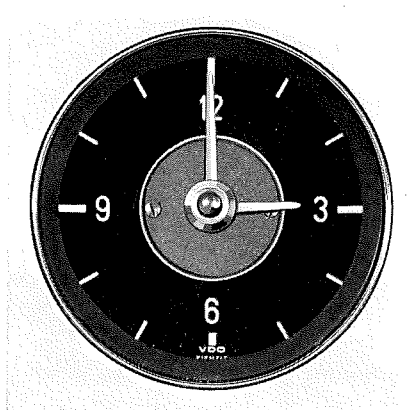

38





You are always within
reach of expert service . . .

. . . wherever your journey takes you.
Our list of authorized BMW service
stations shows you how close-knit
the BMW service organization is.
It lists only workshops to which you
can safely entrust your car.

The man to see is the
BMW SERVICE SPECIALIST.
Your friend in need. Thoroughly
trained to follow your instructions
and answer your questions.
Completely familiar with the BMW
Coupé. You can always rely on your
BMW SERVICE SPECIALIST.

To empty the **ashtrays on the doors**, swing out, press down and remove. **Fig. 39**

The rear seat ashtray is located in the padded centre section below the centre armrest. To empty, pull out as far as the stop, press down the leaf spring and remove. **Fig. 40**

A radio can be fitted to your BMW as an optional extra. Instructions for the model you choose will be supplied together with the car's own documents. **Fig. 41**

39

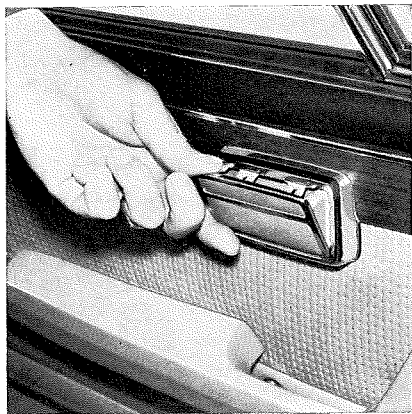

40

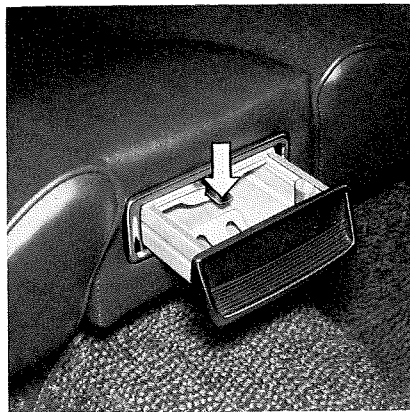

41



The rear seats are provided with a centre armrest, which can be swung down if grasped at the top. **Fig. 42**

42

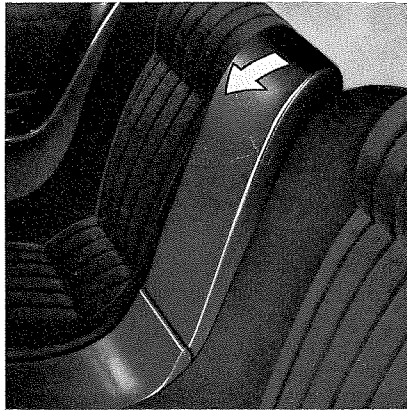

As an optional extra, your BMW can be supplied with a **steel-panel sliding roof**.

Operation:

If the roof is hand-operated, fold the handle down out of its recess in the roof and open the roof by winding counter-clockwise. The roof opens in one continuous movement, and can be halted at any desired point. Turning the crank handle clockwise moves the sliding roof panel forwards to close the roof. The roof is not completely closed until a definite resistance to further movement of the handle is felt. **Fig. 43**

If the roof is electrically-operated, push the rocker switch forward to open and

43

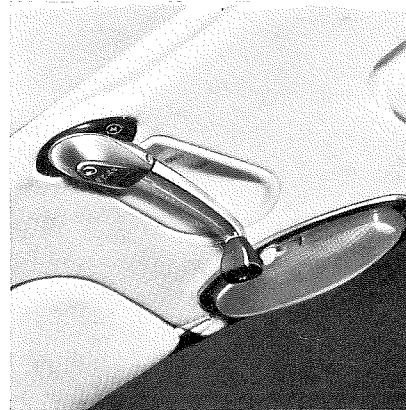

rearward to close. As soon as the switch is released the roof will stop in the position then reached.

If the electric mechanism should fail, proceed as follows:

Open the zip fastener on the roof lining and remove the plastic cap on the sliding roof gearbox. Using a screwdriver, remove the slotted-head screw. Make sure that the washer is not lost and is refitted when the screw is replaced.

Screw in the **hand crank** (supplied as standard) and turn clockwise to close the roof. **Fig. 44**

44

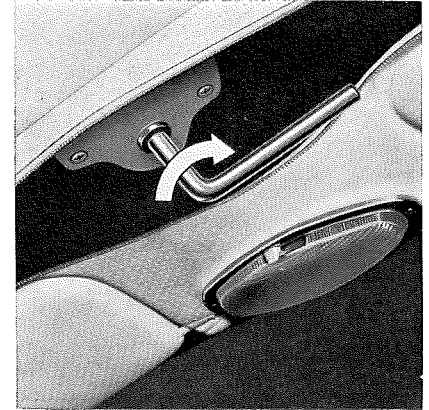

The **heating and ventilation system** on your BMW is notable for exceptional heat output, fine temperature regulation, extremely rapid window demisting and an entirely separate fresh air supply for ventilation in hot weather.

Fig. 45 shows the layout of the controls:

- 1 = Main on/off lever, coupled to blower switch
- 2 = Air distribution lever
- 3 = Temperature selector lever
- 4 = Cold air supply lever
- 5 = Cold air outlet grille

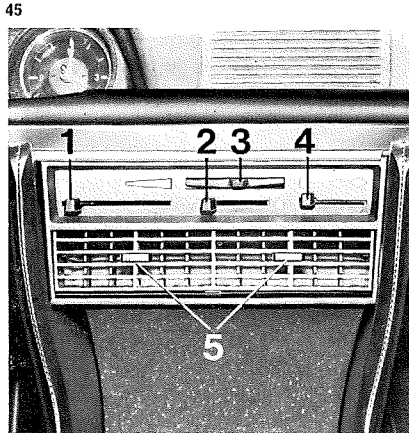

Main on/off lever (1)

Lever to left: all air supply to car's interior shut off. As the lever is moved to the right, an increasingly strong airflow commences. At the mid-point of the lever's travel, stage I of the 3-speed blower cuts in automatically. Moving the lever further to the right switches on stage II of the blower, and when fully to the right stage III is in operation. If possible, do not select stage III of the blower until the engine has reached its normal operating temperature (see page 16). **Fig. 46**

Warning: Make it a rule to switch on the blower whenever heating, defrosting or fresh air supply is required.

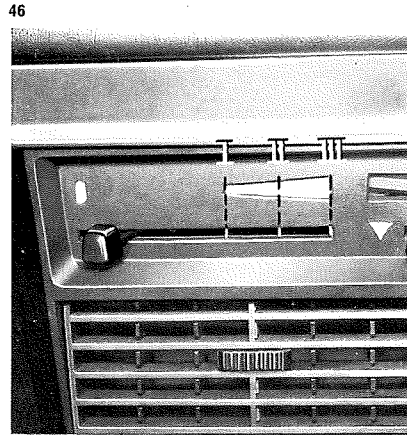

Air distribution lever (2)

By means of the air distribution lever the airflow can be divided in the proportions desired between the footwells and the demister outlets. Equal air distribution is provided when the lever is at its central position (positive stop). If the windows are iced over or heavily steamed up, it is better to direct the full airflow over the windscreen first. **Fig. 47**

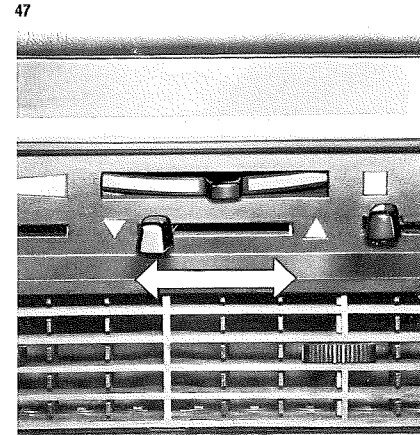

Temperature selector lever (3)

Lever to left (blue zone): cold
Lever to right (red zone): warm
Fig. 48

There is continuous variation of temperature between the two limit positions of the lever, thus providing instant selection of the desired temperature level within the car.

Cold air lever (4)

Lever to left (**positive stop**): cold air supply shut off completely. As the lever is moved to the right an increasing flow of cold air enters through the **fresh air grille (5)**. By tilting and swivelling the guide vanes of the grille or the outlet nozzles, driver and front passenger can obtain a separate flow of fresh air in the direction desired. **Figs. 49 and 50**

The footwell area can be supplied with warm air while the fresh air supply is in use, the temperature depending on the setting of **temperature selector lever (3)**. This ensures stratified heating and ventilation within the car, of great benefit for fatigue-free driving.

Air extraction

When the car is in motion, stale air is extracted from the passenger compartment through slots above the rear window (not on cars fitted with a steel sliding roof) and via ducts in the rear roof pillars.

For further technical details, see pages 90 and 91.

48

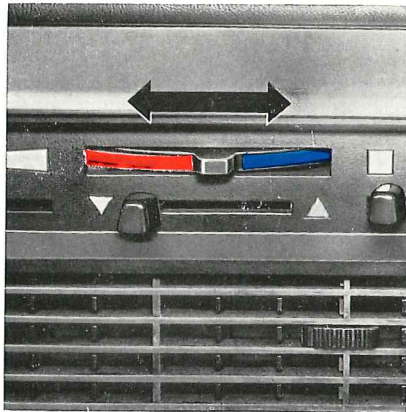

49

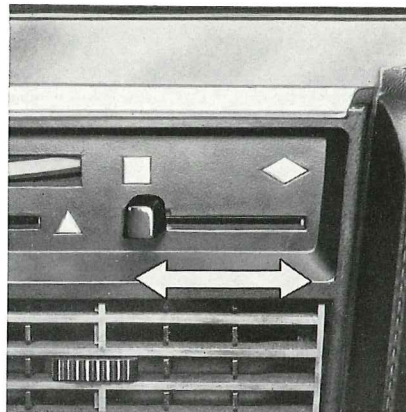

50

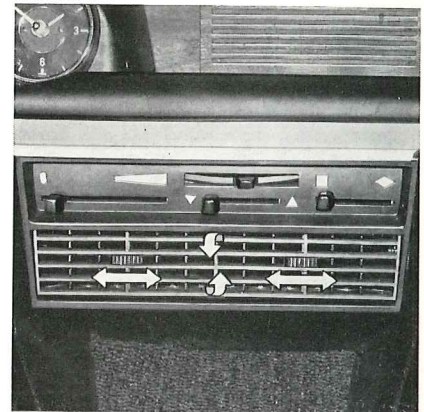

Automatic transmission: the following **selector lever positions** are available to suit various traffic conditions:

P-R-0-A-2-1

The position of the selector lever is shown by the illuminated scale, and is also marked on the lever gate. **Figs. 51 and 52**

Please note the following when operating the **automatic transmission**:

When driving in position A, do not select positions 1 or 2 at speeds of **more than 86 mph (140 kph)**, as this will cause excessive engine speeds.

51



When driving in position 2, do not select position 1 at speeds of **more than 49 mph (80 kph)**, as this will also cause excessive engine speeds.

P = Park

Select only when the car is standing.

The drive train is locked as an additional precaution against running away on a slope. To select position P, press lock button on the left. The engine can still be started.

R = Reverse

Select only when the car is standing,

to do so press lock button on the left. If Reverse is selected while the car is moving forward, the rear wheels will lock – this could cause an accident.

52

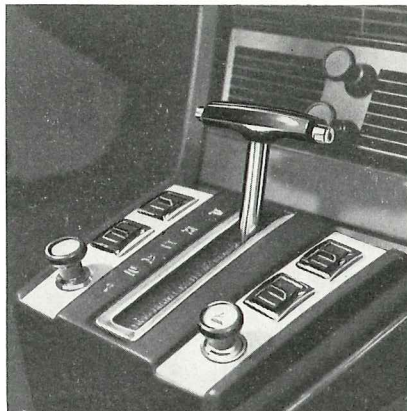

0 = Neutral

The engine is disconnected from the drive train, and can be started. Engage Neutral also when stopping for **lengthy** periods (for instance in traffic jams).

A = Automatic (normal driving position)

This position should be selected for all normal road conditions. The car moves off in 1st gear and automatically changes up into 2nd and 3rd gears as soon as the most favourable and economical point is reached.

2 = Hill-climbing and engine braking

Select this position on mountain roads, or other lengthy rising or falling gradients. Better use is made of available engine power and engine braking effect.

When this position is engaged, the transmission does not move to 3rd gear even if the engine is running at excessive speeds.

1 = Hill-climbing and engine braking

This position is reserved for road and traffic conditions in which it is desirable to remain in 1st gear, for instance very steep uphill or downhill gradients.

At speeds of more than approx. 49 mph (80 kph) the automatic transmission will not move to 2nd or 3rd gears even if the engine is running at excessive speeds.

Kick-down

The accelerator pedal can be pressed down beyond the normal full-throttle position (increased resistance will be felt). In special circumstances, for example when overtaking, more rapid acceleration can thus be obtained; the transmission will select, up to a certain engine speed, the correct gear without any delay.

When the kick-down has been used the subsequent upward changes will occur at a considerably higher road speed than normal, close to the maximum permitted engine speeds in each gear. This ensures that the full available engine power can be made use of when needed.

Towing away

If the car has to be towed away, place the selector lever in the «0» (**Neutral**) position.

Speeds reached when the car is being towed must not exceed 31 mph (50 kph), and the distance covered should be limited to 25–30 miles (40–50 km). For distances longer than 30 miles (50 km), add 3 litres/3.1 US quarts/5.3 Imp. pints of ATF (Automatic Transmission Fluid) to the prescribed content of the transmission, or else remove the propeller shaft.

When the vehicle has been repaired, do not forget to reduce the transmission oil level immediately to the normal prescribed quantity.

Tow starts

The design of the automatic transmission does not permit the engine to be started by towing the car.

Starting off

Before you operate the starter, always make sure that the gear shift lever is in neutral.

On cars fitted with automatic transmission, the engine can only be started when the selector lever is in the «P» or «0» position.

Your BMW 3.0 CS/Automatic is equipped with two carburetors with automatic chokes for cold starting. Please observe the following starting routine.

If the engine is cold, press down the accelerator briefly once before operating the starter; this will actuate the automatic choke and bring it into the «cold start» position.

To start the engine turn the ignition key clockwise to the «Start» position (without pressing down the accelerator a second time) until the engine fires. Do not allow the engine to turn over without firing for longer than about 10 seconds. When the ignition key is released, it will spring back automatically to the «Fahrt» (Drive) position. When a cold engine is started in this way, it will run initially at the relatively high speed of 2500–3000 rpm.

To make starting easier, especially in freezing conditions, switch off all cur-

rent-consuming items and press down the clutch pedal.

When the engine is running, press down the accelerator again (if outside temperature is normal immediately, if rather cold, after a few seconds have elapsed). This will bring the engine speed down to a fast idle.

The carburettor will automatically reduce the engine idling speed to the usual tickover as soon as the coolant temperature has risen sufficiently (needle in the white zone, see page 16).

If the starter has to be operated a second time, the ignition key must first be returned past the «Fahrt» (Drive) position to the «0» position. This deliberate delay is included to prevent as far as possible re-engagement of the starter pinion while the engine is still turning. Try to prevent damage to the flywheel ring or starter pinion teeth by waiting until the engine has ceased to rotate before operating the starter.

If the engine will not start or fires only irregularly after several attempts, try again with the **accelerator pressed down fully**. This will force the choke butterflies open and weaken the fuel/air mixture considerably to prevent flooding. Never inject still more fuel into the intake manifolds by pressing down the accelerator repeatedly.

In severe frost, protect the battery by limiting the first starting attempt to

about 10 seconds. Before a second try is made, wait about 20–30 seconds to permit the battery to recover. The second attempt should be no longer than the first.

If the engine is already warm (normal operating temperature), do not press down the accelerator before operating the starter.

If the engine is very warm, depress the accelerator fully and keep it down while starting.

BMW 3.0 CSI

The **injection engine of your BMW** is fitted with an automatic cold starting and warming-up unit.

Enrichment of mixture when starting

When the engine is started cold and before it reaches normal operating temperature, it requires an enriched fuel/air mixture. For this purpose additional fuel is injected into the intake system by means of a magnetic valve controlled by the ignition current. The duration of this injection process depends on the coolant temperature and is cut off after a certain period to avoid flooding of the engine. It is therefore harmful to

the engine to repeat the starting procedure at short intervals. Rather, operate the starter without a break until the engine fires (max. approx. 20 seconds). During the subsequent warming-up phase an auxiliary air valve – operation of which is likewise dependent on the temperature – increases the idling rev number.

To **start** the engine turn the ignition key past the «Fahr» (Drive) position to the «Start» position.

If the **engine is cold**, always start with-
out pressing down the accelerator.

If the **engine is warm**, start with the ac-
celerator pressed down half way.

When the **engine has started** and is running at a fast idling speed, the oil pressure (orange) and battery charge (red) telltale lamps in the combined instrument should go out.

If the oil pressure telltale lamp glows suddenly during a journey (note however the remarks on pages 11 and 15 concerning operation with a trailer), press down the clutch pedal **immediately** or move the selector lever to the «0» position, and switch off the ignition. If there is sufficient oil in the engine, a BMW service station must be consulted without delay. If the oil pressure telltale glows briefly at idling speeds no fault is

implied provided that the lamp goes out as soon as the engine speed is increased.

If the battery charge telltale comes on during a journey, consult a BMW service station as soon as possible, or else the car's battery may become completely discharged.

It is not recommendable to allow the engine to warm up at idling speed; as soon as the engine is running smoothly, you should move off, using **moderate** engine speeds only. You should only allow the engine to run off load at a fast idling speed for about half a minute if the outside temperature is exceptionally low. This will ensure that lubricating oil has reached all parts of the engine. Never run a cold engine at high speeds as this has the effect of shortening its useful operating life.

Please note that if you start the engine inside a garage a door should first be opened. The exhaust gases contain odourless and invisible carbon monoxide, a highly toxic substance.

To disengage the clutch, always press the pedal fully to the floor; during the journey do not rest the left foot on the clutch pedal.

The driver of a car equipped with automatic transmission should operate both the brake and accelerator pedals **only with the right foot**.

Moving away from a standstill with automatic transmission:

With the engine idling selector positions A, 2, 1 or R can be engaged from P or 0 with **the brakes applied**.

Wait for the gear to engage (noticeable shift) before pressing down the accelerator.

Stopping a car equipped with automatic transmission:

At normal idling speeds with a drive position selected, the car will tend to creep forward on a level surface. The foot brake should be applied lightly to prevent this.

To **stop the engine**, turn the ignition key back as far as the «0» position.

Description of the electronically controlled fuel injection system

The fuel injection system offers a number of advantages:

Increased power output, greater torque, even at low engine speeds, greater elasticity of the engine, smoother running when engine speed increases from idling to partial load and full load, lower fuel consumption, and purer exhaust.

An electronically controlled fuel injection system is particularly advantageous

in the case of engines with 6 or more cylinders, as the electronic system is able to register as large a number of control values as desired at any part of the engine by means of sensors, and can then combine these values in one single programme. It thus offers superior control possibilities.

In the **BMW 3-litre injection engine** the fuel and air are prepared for mixing in two separate units: the electronic fuel injection system and the throttle butterfly manifold.

Then a combustible mixture is formed out of the fuel and the air in the induction manifold, with the fuel being atomised and sprayed onto the intake valves in the manifold under pressure. From this point, the combustion procedure continues in the same way as for every other 4-stroke engine.

The operating principle of the fuel injection system is shown in the diagram on page 33.

1. Fuel delivery

The electrical fuel delivery pump sucks fuel from the tank through the filter in the induction device and the fine-mesh filter in the feed line, and delivers it through the full-flow filter in the delivery line and through the distributor line, to the six injection valves and a starter valve.

A pressure regulator in the distributor line maintains the delivery pressure constant at approx. 2.0 kp/cm² (28.4 psi) and diverts surplus fuel back to the tank. This means that cool fuel, free from vapour bubbles, is available at all times.

If the fuel tank has been run dry, there is no need to bleed off the air but the starter must be continuously operated until the engine starts (max. approx. 20 seconds).

2. Air system

The intake air is supplied through a large-volume air filter, the throttle butterfly manifold (with separate control of air intake at idling speed), to the air vessel. From here, it flows through six induction pipes and induction connections to the combustion chambers.

3. Injection

A control unit serves to ensure that the amount of fuel injected is always in line with the engine operating load. Two release contacts in the distributor control the commencement of opening of the valves and thus the commencement of the injection process. The control unit then determines the injection volume, which depends on how long the electromagnetic injection valves remain open. These valves are switched parallel in two groups of three valve each. The opening time of the injection valves

— and thus the injection volume — is dependent on engine load and is determined by the intake manifold pressure (pressure sensor) and the engine speed (release impulses).

Cold starting and warming up

When the engine is started cold, it needs a much richer mixture. The required fuel/air mixture is then controlled by the two temperature sensors and the secondary airslide.

In addition, an electromagnetic starter valve operated by the temperature retard switch provides further fuel enrichment when starting, the duration of which depends on the engine temperature.

Engine load change

By means of the throttle butterfly switch, the control unit increases the quantity of fuel injected when accelerating.

Whenever the car is coasting downhill, however, only a small quantity of fuel is injected.

The **control unit** calculates injection time on the basis of the values — so-called information — supplied by various sensors and passes on the commands to the injection valves and starter valve.

Information A

The release contacts in the distributor determine the commencement of injection, as a function of the engine speed.

Information B

The injection time (fuel quantity) is determined chiefly by two factors, namely the load condition (information B) and the engine speed (information A). The manifold pressure is a measure of the load condition and is converted by the pressure sensor into an electrical signal which is supplied to the control unit. The electronic control unit controls the injection valves in two groups of three valves each. In this context, the injection valves in each group comprise the three cylinders which succeed one another in ignition sequence.

Group 1: cylinders 1–5–3

Group 2: cylinders 6–2–4

The three injection valves of one group inject simultaneously whilst the inlet valves are still closed. The fuel charge thus created but not yet induced, is then entrained into the combustion chamber by the intake air charge when the corresponding inlet valves open – mixture formation.

Information C

In the coolant circuit there is a temperature sensor I which feeds the

«warming up» information into the control unit. With rising operating temperature, the time of opening of the injection valves becomes shorter and thus the injected quantity of fuel smaller, because on reaching its normal working temperature the engine does not require such a rich mixture.

Information D and E

This information is received by the control unit from the throttle butterfly switch. When the car is coasting, only a very small quantity of fuel is introduced, in order to ensure clean exhaust fumes and a favourable fuel consumption.

During the acceleration phase, however, the information «more fuel» is produced in order to provide a proper transition function.

Information F

With the ignition switched on, the control unit sets the electrical fuel delivery pump into operation via the pump relay (if engine is stationary for one second, see also Command H).

Information L

Temperature sensor I (intake air) in the air vessel adjusts the injected fuel quan-

tity via the control unit, as a function of the air temperature. As the temperature sensor is located after the throttle butterfly, the conditions actually prevailing in the induction manifold are taken into account.

Command G

On the basis of Information B, the control unit provides the injection valves with a command to close after a specific time (thereby determining time of opening).

Command H

The fuel delivery pump is started by the control unit via the pump relay. The pump relay is actuated when the ignition/starter switch is operated (Information F) or when the engine is turning (Information A) e. g. starting or being tow-started.

Information M

Through the timer relay the temperature retard switch provides temperature-dependent fuel enrichment during starting – follow-up injection – up to a coolant temperature of approx. 95° F (35° C).

Control unit information or command

	from	information/command implication
A	Release contacts in distributor	engine speed; commencement of injection
B	Pressure sensor	engine load
C	Temperature sensor II (coolant)	warming up of engine
D+E	Throttle butterfly switch	fuel induction at idling speed and enrichment when accelerating
F	Ignition/starter switch (terminal 50)	electrical fuel delivery pump is switched on
L	Temperature sensor I (intake air)	adjustment of injected fuel quantity as a function of intake air temperature
G	Control unit to injection valves	opening time of injection valves
H	Control unit to fuel delivery pump	starting of fuel delivery pump operation
M	Temperature retard switch and timer relay to starter valve	fuel enrichment during starting and warming up

Description of the fuel injection system

- 1 Fuel tank with induction and anti-rolling unit in the pre-filter
- 2 Fuel delivery pump with fine-mesh filter and pump relay
- 3 Expansion vessel
- 4 Full-flow fuel filter
- 5 Excess pressure regulator with return pipe
- 6 Pressure sensor for intake manifold pressure
- 7 Induction unit
- 8 Cylinder
- 9 Electromagnetic injection valve
- 10 Fuel distributor line
- 11 Control unit
- 12 Distributor with release contacts- 13 Electromagnetic starter valve
- 14 Throttle butterfly switch with fuel enrichment device
- 15 Idling speed/air adjusting screw
- 16 Temperature sensor I (intake air)
- 17 Temperature sensor II (coolant)
- 18 Secondary airslide in coolant circuit
- 19 Air filter for secondary airslide
- 20 Battery
- 21 Main relay
- 22 Ignition/starter switch
- 23 Temperature retard switch and timer relay

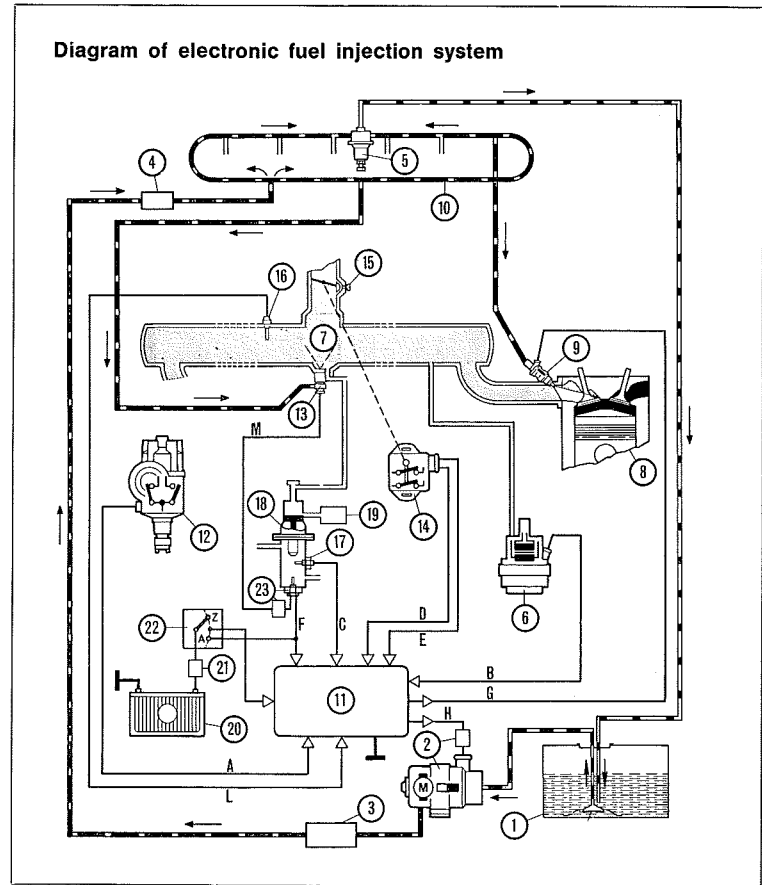

Running-in — but how?

The engine of your **BMW** is not governed, that is to say we have imposed no artificial limitation on its performance. It is therefore up to you to observe the following **running-in rules** conscientiously and thus prolong the working life of your engine and achieve maximum economy.

BMW 3.0 CS

Maximum permitted road speed during the first 600 miles (1000 km):

1st gear	20 mph (35 kph)
2nd gear	40 mph (65 kph)
3rd gear	60 mph (95 kph)
4th gear	80 mph (130 kph)

53

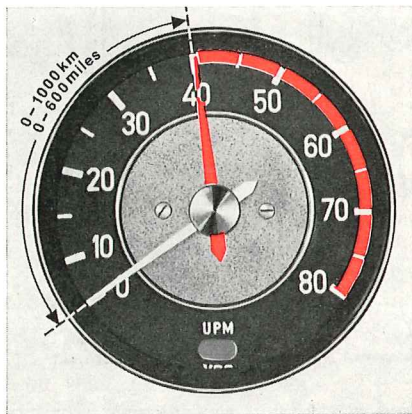

With automatic transmission:

Selector lever positions:

1	31 mph (50 kph)
2	53 mph (85 kph)
A	80 mph (130 kph)

Maximum permitted road speeds between 600 and 1200 miles (1000—2000 km):

1st gear	25 mph (40 kph)
2nd gear	45 mph (70 kph)
3rd gear	65 mph (110 kph)
4th gear	95 mph (150 kph)

With automatic transmission:

Selector lever positions:

1	38 mph (60 kph)
2	62 mph (100 kph)
A	95 mph (150 kph)

54

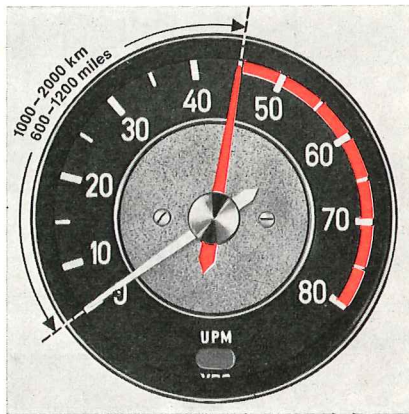

BMW 3.0 CSI

Maximum permitted road speeds during the first 600 miles (1000 km):

1st gear	20 mph (35 kph)
2nd gear	40 mph (65 kph)
3rd gear	62 mph (100 kph)
4th gear	92 mph (145 kph)

Maximum permitted road speeds between 600 and 1200 miles (1000—2000 km):

1st gear	25 mph (40 kph)
2nd gear	47 mph (75 kph)
3rd gear	68 mph (115 kph)
4th gear	100 mph (160 kph)

You should use the maximum permitted speeds in each gear only for limited periods while running in. Vary your road speed as often as possible. Use different engine speed ranges and change down in good time, especially on uphill gradients.

Do not use kick-down position of the accelerator (see page 27) at all during the first 1200 miles (2000 km).

You can read off engine speed at any time on the **revolution counter**. The following **engine speed limits** should be observed **during running in**:

0—600 miles — 4000 rpm **Fig. 53**
(0—1000 km)

600—1200 miles — 4000 rpm **Fig. 54**
(1000—2000 km)

Allowing the engine to pull hard at very low speeds in a high gear is at least as harmful as exceeding the specified limits. Try to keep above 1500 rpm while on the move.

Running in the brakes: Until above 300 miles (500 km) have been covered, avoid repeated violent brake applications, especially from high speeds, and do not subject the brakes to extended tests, or the linings may not develop their correct wear and friction coefficients.

During **running in** the gear shift lever, steering etc. may be a bit **stiff to move**. As running in proceeds, however, this effect will become less noticeable and disappear after a short period of operation.

From a speedometer reading of approx. 1200 miles (2000 km) onwards you may **gradually** increase road speed up to the permitted **top speed**, provided road and weather conditions allow.

BMW 3.0 CS

4th gear 132 mph (213 kph)
Selector lever position A
128 mph (207 kph)

BMW 3.0 CSI

4th gear 136 mph (220 kph)

The **maximum continuous engine speed** is 6000 rpm.

Corresponds to:

	BMW 3.0 CS	BMW 3.0 CSI
1st gear	31 mph (50 kph)	34 mph (55 kph)
2nd gear	56 mph (90 kph)	62 mph (100 kph)
3rd gear	92 mph (145 kph)	96 mph (155 kph)
4th gear	124 mph (200 kph)	133 mph (215 kph)

With automatic transmission:

BMW 3.0 CS A

Selector lever positions:

1 50 mph (80 kph)
2 84 mph (135 kph)
A 121 mph (195 kph)

Never use engine speeds in the red zone of the revolution counter, that is to say above 6400 rpm; be particularly careful on long main road downhill gradients and in the intermediate gears. **Fig. 55**

Maximum permitted road speeds after running in is complete:

BMW 3.0 CS

BMW 3.0 CSI

1st gear	34 mph (55 kph)	38 mph (60 kph)
2nd gear	62 mph (100 kph)	65 mph (105 kph)
3rd gear	96 mph (155 kph)	102 mph (165 kph)
4th gear	132 mph (213 kph)	136 mph (220 kph)

With automatic transmission: BMW 3.0 CS A

Selector lever positions:

1 56 mph (90 kph)
2 92 mph (145 kph)
A 128 mph (207 kph)

55

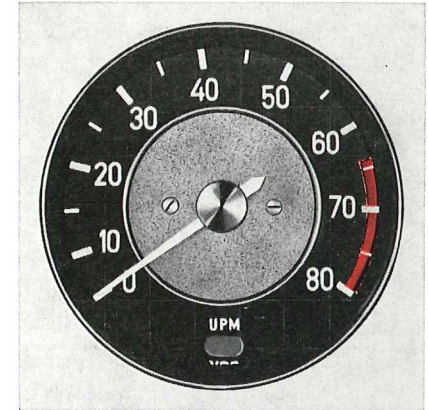

On your way

For satisfactory operation the engine must be supplied with a **premium (super) grade fuel** having a minimum octane number of 99 (Research Method).

If you are obliged to fill up with fuel having a lower octane number, and thus with lower knock resistance, the following hints will assist in avoiding pre-ignition or «pinking» as far as possible: Keep the engine turning at 2500 rpm or over, change down in good time, accelerate gently and carefully. A graph of road speed/engine speed is shown on page 82 (BMW 3.0 CSi) and page 84 (BMW 3.0 CSi).

Your car's **fuel economy** is mainly dependent on your style of driving. Just as travel by the fastest trains involves payment of a supplement, so high-speed driving, acceleration to the limit in all gears (see page 35), violent cornering and sudden braking all take their toll, not only in terms of heavy fuel and oil consumption, but also more rapid wear of brakes, tyres and other moving parts.

Fig. 56 shows the **fuel consumption** expressed in terms of road speed, for a vehicle in standard trim with driver and one passenger.

The **standard test method** (German Industrial Standard DIN 70030) for determining **fuel consumption** is in no way identical with the actual average fuel consumption, which is influenced by a number of factors such as driving style, load, road condition, traffic density and flow, weather, tyre pressure etc.

After driving for some time in dense city traffic or in a queue of cars, we recommend letting your engine «**take a deep breath**», as it were, by covering the next mile or two at engine speeds of 4500–5500 rpm. This will help to disperse any carbon build-up in the cylinders.

Observance of the **prescribed tyre pressures** does not only influence tyre life, but also handling, fuel consumption etc. Make it a habit before starting any long journey, and in any case at least once a week, to check tyre pressures. You will find a list of correct pressures inside the fuel filler flap and on the inside back cover of this handbook.

56 Fuel consumption at steady speeds

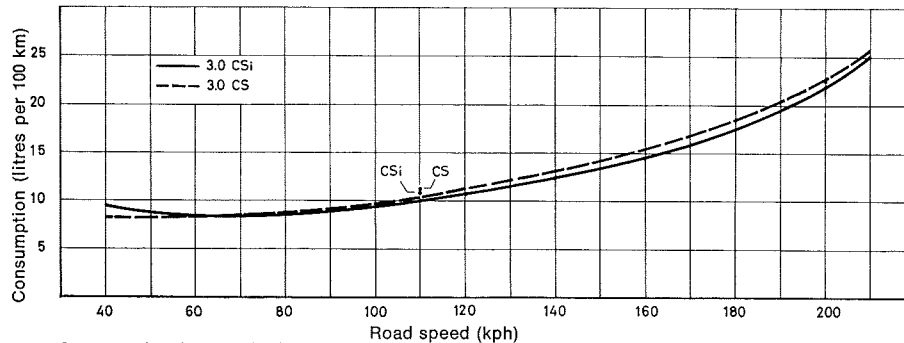

o = Consumption by standard test method

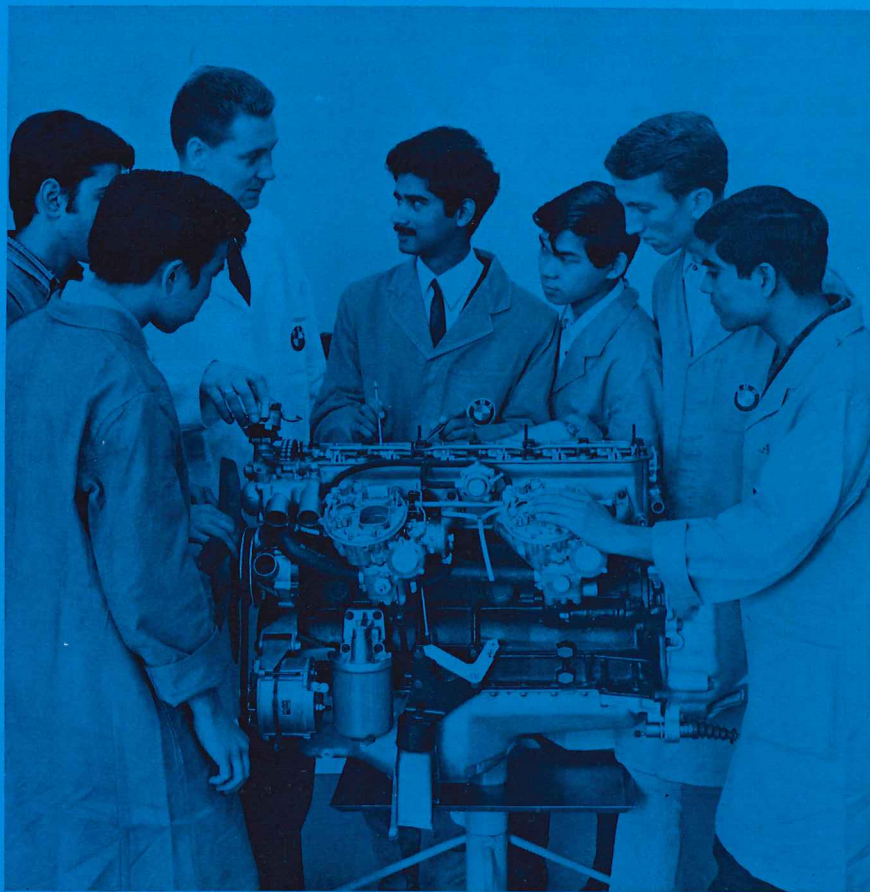

Training — BMW style

The BMW service organization is world-wide. The training programme for BMW personnel is world-wide too. Continuous training is our motto.

The diploma awarded for a training course successfully completed is not easy to come by. Next time you visit one of our authorized service stations, look for such diplomas on display and see for yourself.

Engine oil consumption, like fuel consumption, depends on a variety of factors.

At regular intervals, we suggest that the oil level be checked (**Fig. 57**) and topped up with fresh oil of the same grade if required. Add oil through the filler cap on the valve rocker cover until the level reaches the upper marking on the dipstick (for oil grades, see page 61). To ensure most accurate measurement of the oil level, hold the dipstick with the rounded grip section facing to the left. It is useless to overfill the engine with oil and can in certain circumstances even lead to damage. The quantity of oil represented by the space between the upper and lower markings on the dipstick is 1.5 litres, 1.1 quarts (US) 2.6

57



pints (Imp.). Never let the level fall below the lower marking on the dipstick and never remove the oil filler cap while the engine is running.

Change to another type of oil only when a routine oil change, including the filter element, is carried out.

The design of our engines is such that, provided a modern highly-developed branded engine oil is used, **no oil additives** are necessary. This also applies to the hydraulic power steering, manual gearbox, automatic transmission, and final drive.

Check the oil level in the automatic transmission (Fig. 58, see also page 62) and the hydraulic power steering (see

58

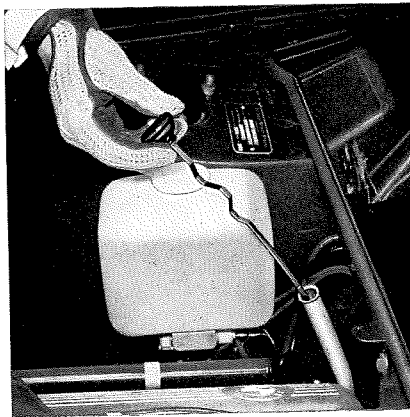

page 63) at the same time as the engine oil level.

A well-tryed rule: after a lengthy spell on a **high-speed motorway or mountain pass, using full throttle**, do not switch the engine off immediately on halting, but allow it to idle or run under light load for a few minutes. This will prevent the formation of heat pockets in the engine and resulting loss of coolant.

Warning: To open the radiator cap when the engine is hot, use a glove or cloth and turn the cap at first only through a quarter-turn counter-clockwise, as far as the first stop. Allow excess pressure to disperse, then turn further and remove the cap. To replace, screw on fully as far as the second stop. On **downhill gradients**, engine braking effect can be increased by changing down to a lower gear. Never coast downhill with the clutch pedal depressed, the gear shift lever in neutral or the ignition switched off.

After a lengthy journey on wet roads, in rain or slush, the first brake application may call for somewhat more pedal pressure than usual.

If one circuit of the hydraulic twin dual-circuit brake system should fail, pedal travel increases immediately. To produce the desired retardation, greater **pedal pressure** will also be called for. Although the braking performance of the vehicle with only one circuit in operation remains entirely adequate, you should submit the car for repair to an authorized service station without delay.

When the **minimum brake pad thickness** is reached, a spreader spring in each disc brake caliper comes into operation and causes **increased pedal pressure** to be felt. To protect the discs from damage the pads should then be renewed without delay by an authorized BMW service station.

The brake servo of your BMW operates pneumatically, so that the necessary vacuum is produced only with the engine running. If the vehicle is moved with a dead engine, for instance when being towed away, note that heavier pedal pressure will be needed to achieve the desired braking effect.

59

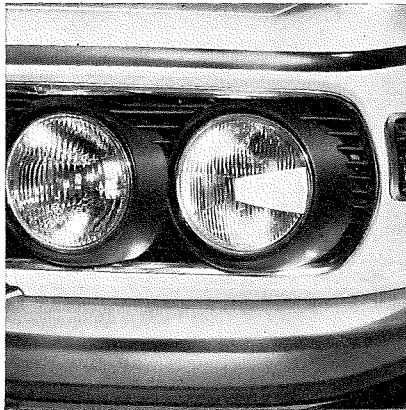

When undertaking a lengthy **journey abroad**, we suggest that you carry with you in the car a number of spare parts — V-belts, gaskets etc. are useful. Your BMW service station will gladly assist you in selecting the most suitable items.

Most foreign countries you will visit require the international registration disc of the country in which the car is licensed to be displayed at the rear. However, certain countries have additional regulations which must be observed, and in such cases information is obtainable from car clubs, consulates etc.

If you should take your car into a country where they drive on the opposite side of the road, you should not drive at night before covering up the wedge-shaped areas on your headlights with adhesive tape. If this is not done, the asymmetric dipped beams will dazzle oncoming drivers. **Fig. 59** shows how to mask off the headlight lenses when taking a left-hand-drive car into a country where they drive on the left.

Before attempting any **engineering modifications** to your car or **changing the dimensions of the tyres etc.**, always consult a BMW service station first. They will be able to advise you on the value, the legal position and the factory's attitude regarding your proposed modification.

Your BMW 3.0 CS/i is fitted with **hydraulic power steering**.

A frequent necessity in today's traffic, particularly in crowded city centres, is manoeuvring and parking the car in a very limited space. Usually, the steering must be turned several times from lock to lock while the vehicle is at a standstill or moving very slowly. At other times, an unexpected emergency situation may call for an instant change of direction at high speed if a collision is to be avoided. If as a result one front wheel should run off the road on to an uneven surface, sudden and violent lateral forces in one direction may be applied to the steering. With hydraulic power steering, the driver will in both cases only feel a slight additional resistance at the steering wheel rim, since all his movements are assisted by hydraulic servo action.

This power assistance not only contributes greatly to effortless driving, but also constitutes a substantial safety factor.

If the BMW 3.0 CS/CSi is your first car with hydraulic power steering, please note that you may need a little time to become used to its light action when driving the car.

Construction:

The housing of the ZF ball and nut power steering gear contains a control valve and hydraulic cylinder in addition to a complete mechanical steering mechanism. Oil under pressure for steering movements is supplied by a ZF high-pressure vane-type pump driven by V-belt from the engine. The oil reservoir with filter is attached to this pump.

The design of the steering gear is such that any fault in the hydraulic system or drive to the pump (engine failure requiring towing away of the vehicle) does not prevent full manual steering from being available, although the effort required is then naturally enough correspondingly higher.

Check oil level in the hydraulic power steering reservoir at the same intervals as the **engine oil**, and as part of the **routine maintenance procedure** (see page 63). For initial and subsequent filling and for topping up — less than ¼ litre (0.44 Imp. pints/0.52 US pints). use only the oils listed on page 105.

Every 40 000 miles (60 000 km), the oil filter element of the hydraulic power steering should be renewed and the steering carefully checked for correct operation. This operation, and all other work on the steering, should only be

carried out by an authorized BMW service station.

Automatic cooling fan coupling

To ensure maximum performance and running silence, and at the same time minimum fuel consumption, the engine is equipped with an automatic fan coupling. Over a wide range of road speeds the flow of air through the radiator and normal heat dissipation from the engine are enough to provide adequate cooling. It is only in traffic jams and during lengthy spells of mountain pass climbing that the natural airflow needs to be reinforced by the action of a fan. The automatic coupling is completely maintenance-free in use, and cuts in and out by the action of an expansible element. Power normally wasted on driving the fan is thus released to propel the car, and fuel consumption is reduced accordingly.

An additional advantage is that the engine reaches its normal operating temperature more rapidly, and is no longer overcooled during the cold season of the year or when descending lengthy mountain passes.

The Automatic models are equipped with an electric auxiliary fan to increase the cooling effect under unfavourable conditions. This fan cuts in automatically when the coolant temperature reaches approx. 212° F (100° C)

and is switched off when the temperature drops to approx. 198° F (92° C).

Your BMW Coupé can be fitted with a ZF Lok-O-Matic disc type **limited-slip differential** on request.

Bad road conditions can mean that one wheel on a car fitted with a normal differential is not able to transmit its share of the driving force without spinning. In certain circumstances a spinning wheel can be inconvenient or dangerous, and can largely be avoided by fitting a limited-slip differential.

The locking action of the limited-slip differential is derived from internal friction dependent on load, and produced by the action of the equalizing shafts, thrust rings and symmetrically positioned friction discs.

Thanks to the internal friction of the disc and the outward thrust generated by the differential bevel pinions, wheelspin is retarded or totally avoided. The outward thrust is therefore proportional to the total torque being transmitted to the wheels.

The limited-slip differential is of particular value in that it operates as and when required, without any action on the part of the driver.

For **winter operation** of your car, a few essential steps must be taken in good time before the cold season commences. The cooling water, as delivered, contains a **long-life antifreeze and corrosion inhibitor**.

Total capacity of cooling system including heater:	21.1 pints (Imp.) 25.4 pints (US) 12 litres
Frost protection down to approx.:	-13° F -25° C

Your BMW service station can recommend factory-approved brands of antifreeze. Change the coolant completely every **2 years**. (For draining and refilling the cooling system, see pages 66 and 67.)

Check the antifreeze properties of the coolant before and during the cold season of the year. At the same time, examine the cooling system for leaks and replace any porous or brittle hoses.

Engine temperature is controlled by thermostat, taking into account both engine load and outside temperature. For this reason **the grille must not be blanked off, nor a radiator blind fitted**.

The **screenwasher** can be protected in alcohol spirit. This is effective down to temperatures in the region of -20° C (-4° F). Use 1 litre/1.1 US quarts/1.8 cold weather by adding 40% domestic

Imp. pints for a fluid reservoir capacity of 2.5 litres/2.6 US quarts/4.4 Imp. pints.

Please note the **instructions regarding engine oil** to be followed at the beginning of the cold season (see page 61).

If the weather suddenly turns colder, do not wait until the next routine oil change before refilling with a suitable grade of oil.

If the engine is to start reliably in winter, the **battery** must be fully charged. When cold, a battery's output is reduced, yet the demands made on it are greater in winter than in summer.

Warning: To charge the battery **without removal** from the car, the engine must be stopped, then **both battery terminals removed. Never attempt to disconnect** the battery terminals **while the engine is running**.

If **winter tyres** – either winter tread pattern radial (M+S) or spiked radial (M, S+E) – are installed, please note that for good directional stability and light action steering tyres of the same make and type should be fitted to **all four wheels** (and to the spare as well if possible).

Do not exceed the maximum speeds laid down by law or recommended by the tyre manufacturer. Radial spiked tyres (M, S+E) should be run in at moderate speeds for approx. 200 miles (300 km).

When the winter tyres are removed, mark the direction of rotation on the carcasses so that they can later be installed in the same position. The spikes bed down in the rubber and will then need no subsequent running in.

Observe the prescribed tyre pressures at all times, and have the wheels rebalanced whenever a wheel or tyre is changed.

Note the tightening torques of the wheel nuts and check after 600 miles (1000 km) and every 4000 miles (6000 km).

Use **snow chains** only on the driving wheels and only together with 175 SR 14 winter radial tyres – either winter tread pattern radial (M+S) or spiked radial (M, S+E) – and do not exceed approx. 45 mph (70 kph).

When leaving your car **parked in freezing conditions**, engage 1st or reverse gear to prevent it from rolling away, or select automatic transmission position <P>, but do not apply the handbrake. There is a risk that the handbrake shoes may freeze solid to their drums.

Use only factory-approved products for the **locks** (your BMW service station can advise you), so as to avoid difficulties in functioning. These products will prevent the locks from freezing. If a lock freezes up despite these precautions, heat the key blade before insertion.

It is suggested to rub glycerin onto the rubber parts to prevent the **sealing rubber strips** on the doors and around the engine compartment and luggage compartment from freezing tight.

In winter, **chromium plated and polished components** can be protected with colourless lacquer.

Your car is treated as standard with a **special coating on all cavities and inside surfaces**, and the **underside** is covered with a **one-season underseal coating**. This treatment must be renewed at the latest 8 months after your car has been registered and then every 12 months, in order to guarantee that your BMW keeps its value.

Details on this procedure can be seen from the documents provided together with your car, which have been compiled according to the national specifications applicable in the case of your vehicle. Your BMW service station knows the factory-approved products and preservation requirements.

Whenever new underseal is applied, the disc brakes should be carefully shielded. No form of preservative should be allowed to reach the sealing sleeves on the brake pistons or the brake discs themselves.

Spraying with oil-based compounds offers no lasting protection against rust damage, and in fact attacks rubber com-

ponents on the underside of the car and causes the existing underseal to become loose.

After a heavy fall of snow, clear the air inlets in front of the windscreen so that the car's heating and air extraction systems can function correctly.

In winter, we also suggest carrying the following items in the car:

- Sand, for starting on ice-covered slopes;
- A shovel to dig the car out of drifts;
- A board to act as a firm support for the jack;
- Handbrush and scraper to remove ice and snow from the body and windows.

What to do, if . . .

If your car should develop a fault which you are capable of dealing with yourself, proceed as follows if no service station is accessible.

Tyre trouble is a rare thing these days. But if you should be unlucky and suffer a flat tyre, pull in to the side of the road and apply the handbrake. Do not forget to switch on the hazard warning flashers (see page 14) and to set up a warning triangle or flashing signal lamp at an adequate distance to the rear, if these measures are required by law.

60

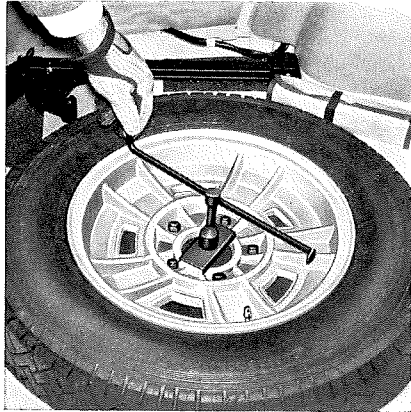

Spare wheel, speed wrench for wheel nuts, and jack are housed in the luggage compartment, under the left hand floor panel. This panel is retained by spring clips and should be pulled up to remove.

The hexagon nut which secures the spare wheel should be unscrewed with the speed wrench, and serves as a spare wheel nut in case one is lost during wheel-changing. **Fig. 60**

Carefully force off the hub cap with the hook on the speed wrench, supporting the cap with the other hand (**Fig. 61**), and **loosen** the wheel nuts slightly.

61

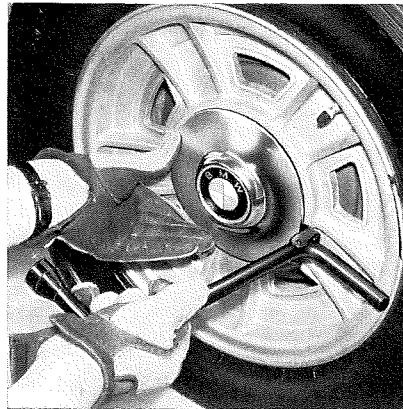

Fit the jack to one of the **4 lifting points** provided on the body, and turn with the speed wrench until the defective wheel is clear off the ground. **Fig. 62**

Remove the wheel nuts and change the wheels. Replace the wheel nuts and tighten evenly until the wheel is held firmly. Lower the car until the wheel is supporting the load, then **finally tighten the wheel nuts**, working in a crosswise pattern. Have the tightening torques checked by a service station right away, and have them checked again every 8000 miles (12000 km) at a BMW Program Test. Replace the hub cap, and secure by striking lightly at the rim. The flat tyre should of course be repaired as soon as possible.

62

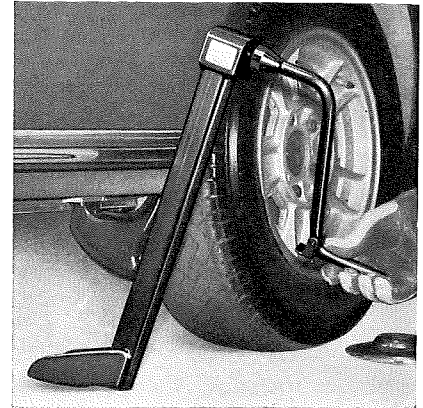

The toolkit is housed in a case beneath the luggage compartment lid, and can be opened by unscrewing the wingnut. As well as the tools necessary for minor repairs it also contains a number of spare fuses, bulbs and spark plugs. **Fig. 63**

Starter motor does not operate when ignition key is turned to «Start»:

Check by switching on headlights, then operating starter again.

1. If the headlights go out quite slowly, the battery is insufficiently charged or defective. Recharge the battery or have it changed. The car can be push-started or towed if necessary. Owing to the design of the **automatic trans-**

mission, cars fitted with this optional extra cannot be push-started or towed for starting, and must be towed away for repair (see page 27). **Towing eyes** are located on the left and right hand sides of the front axle beam. **Fig. 64**

To tow-start a manual transmission car, declutch and select third gear. When the car is moving forward smoothly, engage the clutch.

2. If the headlights go out immediately, check the cable terminals on the battery and starter motor for tightness, and take up any slack.
3. If the brightness of the headlights does not diminish, consult your BMW service station (a fault in the starter is indicated).

Engine will not start although starter motor is turning:

Provided that the instructions for starting on pages 28 and 29 were observed, and there is enough fuel in the tank, the fault may lie in the ignition system or the fuel supply system.

1. Check that the plug leads are firmly attached to the spark plugs. Check the tightness of all cables on the coil, distributor and other terminals, and ensure that the fault is not due to water present in the engine compartment.
2. Check spark plug gaps and general appearance (see page 69).
3. To test each spark plug for correct operation, unscrew in turn, reconnect to plug lead and rest the metal exterior of the spark plug on the bare metal of the engine block. When the starter is operated, sparks should be seen to jump the electrode gap. If no spark is visible, try another plug on the same cable. If once again no sparks are to be seen, the distributor should be examined (see page 70).
4. To check fuel supply, detach the fuel feed pipe to the carburettors and operate the starter. If no fuel emerges from the open end of the pipe, check the supply line from the tank and the fuel pump (see page 68). If fuel does emerge, the carburettor jets should

63

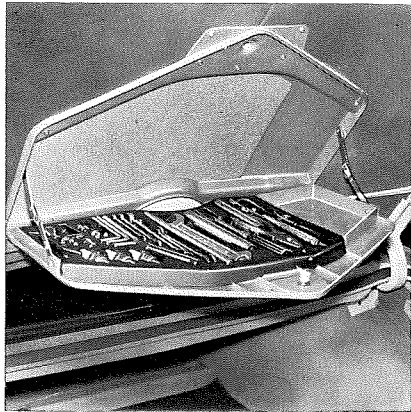

64

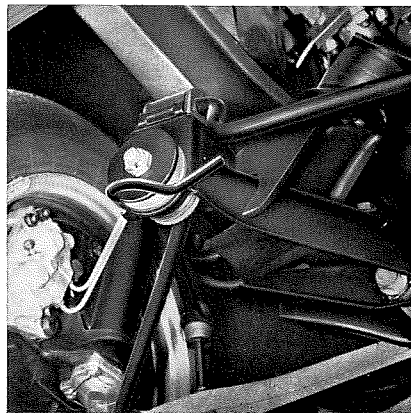

be unscrewed and cleaned. We recommend entrusting this work to an authorized BMW service station.

BMW 3.0 CSI

Engine will not start although starter motor is turning:

Provided that there is enough fuel in the tank and there is no fault in the ignition system, check the fuel supply. To do this, listen for a slight buzzing noise lasting approx. 1 second immediately after having operated the starter. This indicates that the fuel pump is working and will switch off after 1 second. If no such noise is to be heard, check whether the fuse for the fuel pump (see key to fuses) has blown.

Should the fuse be in good condition, check electrical supply cable to pump (including terminals and ignition/starter switch). If, on the other hand, the fuel pump is working, check the fuel flow pipes and connection hoses for leakage and inspect the full-flow filter. If no fault is to be found here either, contact a BMW service station.

Coolant temperature too high:

1. Carefully remove the radiator cap and check coolant level. Never add water to the system **if the engine is hot**, after having lost a large quantity of coolant. Allow the engine to cool until a hand can be placed on the block.

2. If coolant is lost, check the radiator cap, all hose connections and the radiator for leaks.
3. Check that the automatic fan coupling is engaged or, in the case of the BMW 3.0 CS A, whether the electrical auxiliary fan is functioning correctly.
4. Check V-belt condition and tension; adjust or renew as required (see page 74).
5. Check ignition timing (see page 70).
6. If necessary, have the complete cooling system flushed out by your BMW service station.

Some hints on rectifying faults in the hydraulic power steering

Steering heavy to turn on right or left lock:

Not enough oil in the system. Check oil level (see page 63), and if necessary examine the steering gear for leaks or possible damage.

V-belt inadequately tensioned or defective. Retension or renew (see page 74).

Steering heavy when steering wheel is turned quickly:

V-belt inadequately tensioned or defective. Retension or renew (see page 74).

Unusual noises:

Not enough oil in the system. Top up and check steering gear for leaks.
Oil filter clogged with dirt: renew.

If these measures do not rectify the trouble, always consult a BMW service station without delay.

Brake system defective:

If the red «brake» telltale lamp glows when the vehicle is in motion, and the handbrake has been correctly released, loss of brake fluid or — if free travel of the brake pedal is considerably longer than normal — failure of one hydraulic brake circuit is indicated.

Whenever a fault develops in the brake system we recommend you to consult the nearest service station as a matter of urgency.

Car stuck in deep snow, sand, mud etc.: Do not press the accelerator down too far; before the rear wheels sink in too deeply, place some form of support beneath them (in an emergency the car's floor mats can be used). It may help to apply the handbrake lightly to stop one rear wheel from spinning. If this remedy works, do not forget to release the handbrake immediately afterwards.

Towing another car:

If you wish to assist another driver by towing his car with your BMW, you should ensure first of all that the second car is not heavier than your own. A rear **towing eye** is located under the spare wheel pan. **Fig. 65**

To remove a **wiper blade** by pulling it off in an upward direction, first lift the complete arm away from the windscreen. Then press back the centre section of the blade at the top, and at the same time lift the safety catch. **Fig. 66**

The complete **wiper arm** can be removed from its shaft if the spring clip is first raised slightly. **Fig. 67**

65

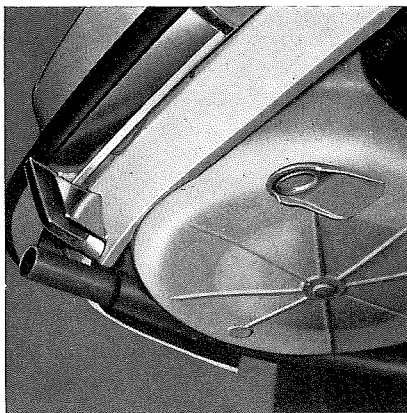

66

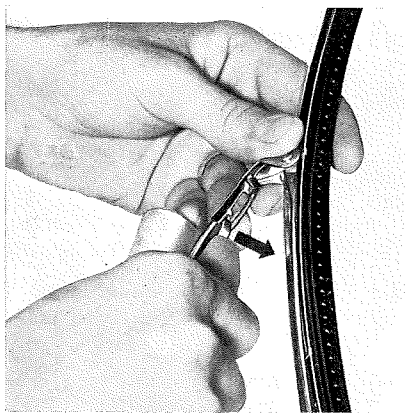

67

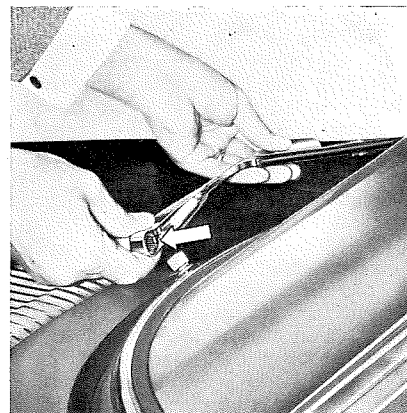



Where fine cars and
fine car experts meet . . .

. . . at the final inspection in one of
the modern BMW Service Stations.
The specialist is responsible
for checking all the important
functions on YOUR BMW Coupé.
He uses foolproof inspection
techniques specially developed by
BMW for the "New Range" models.

The final inspection ticket attached
to your car's steering wheel is your
guarantee of a lot more sheer
driving pleasure still to come.

If any current-consuming item on your car should fail, first check the fuse. **The fusebox** with spare fuses is located in a damp-proof case in the passenger compartment of the car, under the instrument panel, and can be reached by opening the small stowage compartment. **Fig. 68**

A blown fuse can be recognized by the melted metal strip visible through the transparent plastic cap. Pull the blown fuse out of its metal clips and press in a replacement. Never replace a blown fuse with wire or a similar makeshift remedy (risk of fire). If the fuse blows repeatedly, the cause should be investigated by a specialist workshop.

68

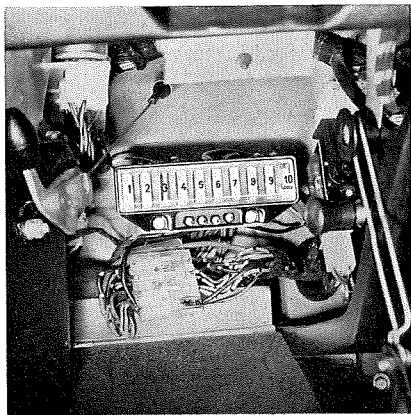
**Key to fuses:**

No.	Fuse (to DIN 72581 standard)	Item of electrical equipment
1	5 Amp (yellow)	Left hand rear, parking and side lights, engine compartment lighting
2	5 Amp (yellow)	Licence plate lights, instrument lighting, control lighting
3	5 Amp (yellow)	Right hand rear, parking and side lights
4	8 Amp (white or black)	Clock, interior light, glove box light, hazard warning flashers, luggage compartment lighting
5	16 Amp (red)	Cigar lighter, automatic radio aerial
6	16 Amp (red)	Screenwiper motor, screenwasher, stop lights, turn indicators, reversing lights, horn relay
7	8 Amp (white or black)	Fuel gauge and coolant thermometer gauge, oil pressure, brake and fuel level telltales, selector lever indicators. automatic chokes on BMW 3.0 CS electric fuel pump on BMW 3.0 CSI
8	25 Amp (blue)	Heated rear window, spare fuse for air conditioning, electric window lifts (left side)
9	25 Amp (blue)	Heater blower, electric window lifts (right side)
10	16 Amp (red)	Electric sliding roof and other items of electrical equipment

When **changing a bulb** or carrying out any other work on the car's electrical system, always switch off the item involved or detach the earth lead from the battery negative terminal to avoid short circuits.

Never handle new bulbs with bare hands; use a clean cloth, paper napkin or similar to avoid depositing grease. When changing headlight bulbs, make sure that the beam setting screws are not disturbed.

Spare bulbs for an emergency are carried in the toolkit under the luggage compartment lid.

Instrument lighting:

To change the bulbs, first remove the padded cover below the instrument panel. Pull out the defective bulb in its holder from the back of the affected instrument. The bulb is removed from the holder by pressing in slightly and turning.

Combined instrument:

Lighting: 2 indicator-type bulbs (H), 2 Watt; Oil pressure telltale: 1 indicator-type bulb (H), 2 Watt; Battery charge telltale: 1 indicator-type bulb (HL), 3 Watt; Fuel level telltale: 1 indicator-type bulb (H), 2 Watt; Headlight main beam: 1 indicator-type bulb (H), 2 Watt.

Speedometer:

Lighting: 2 indicator-type bulbs (H), 2 Watt; Turn indicator repeater: 1 indicator-type bulb (H), 2 Watt.

Revolution counter:

Lighting: 1 indicator-type bulb (H), 2 Watt; Brake system telltale: 1 indicator-type bulb (H), 2 Watt.

Clock:

Lighting: 1 indicator-type bulb (H), 2 Watt.

Control lighting:

Remove the lower steering column housing (4 Phillips head screws). Pull out the bulb holder and replace the 2 Watt valve-base bulb.

Switches for fog lights and rear fog warning light, heated rear window and warning flashers:

Unscrew the appropriate pushbutton and withdraw the valve-base bulb. Each switch is fitted with a 1.2 Watt, 2 x 4.6 d (W) bulb.

Selector lever indicator lights (automatic transmission):

Unscrew the Phillips head screws at the sides of the indicator light housing and take off the upper section. Press the defective bulb in slightly and turn to remove.
6 valve-base bulbs (W), 2 x 4.6 d, 1.2 Watt

Glove box lighting:

Pull the lamp away from the rear wall of the glove box and replace the 5 Watt festoon-type bulb (L).

The **dipped** beams are provided by the outer pair of headlights, which also house the bulbs for the **side and parking lights**.

Open the engine compartment, turn and pull the cover off to the rear — bayonet lock — and detach the appropriate cable connector. The H 1 55 Watt quartz-iodine bulb is retained in the reflector by a spring clip, and can be removed by hinging the spring back and withdrawing the bulb rearwards. When replacing, note the position of the cutout in the reflector. **Fig. 69**

69

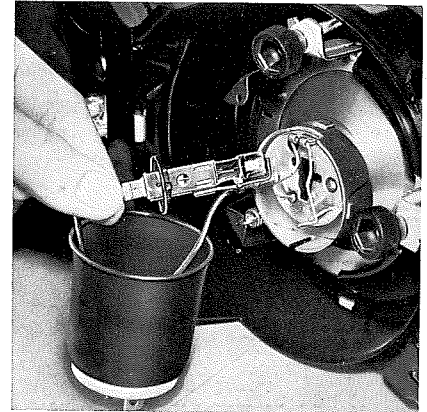

To change a **side or parking light bulb** — 4 Watt (HL) indicator-type — pull the holder and the bulb out of the reflector and remove the bulb while pressing in slightly (**Fig. 70**). After changing the bulb and replacing the cover, connect the cables as follows:

Earth cable — round plug at side;
Dipped beam cable — flat plug at top;
Side/parking light cable — flat plug at bottom.

The **main-beam headlights** — the inner units — come on in addition to the dipped beams.

To change the bulbs, open the engine compartment, turn and pull off the

70

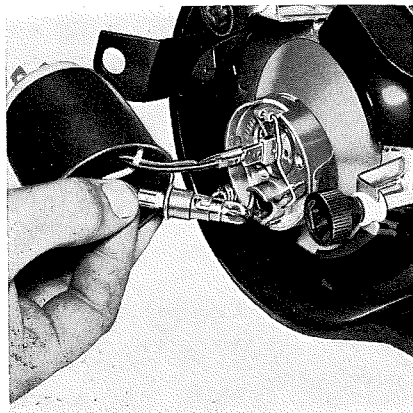

headlight unit cover to the rear — bayonet lock — after loosening the two knurled nuts, and disconnect the appropriate cables.

The H 1 55 Watt quartz-iodine bulb is retained in the reflector by a spring clip, which should be swung back so that the bulb can be withdrawn rearwards. When replacing, note the position of the cutout in the reflector.

Front turn indicators:

Unscrew the two Phillips-head screws holding the plastic lens, and remove the lens with its seal. The 21 Watt (RL) spherical bulb should be pressed in slightly and turned to remove. **Fig. 71**

71

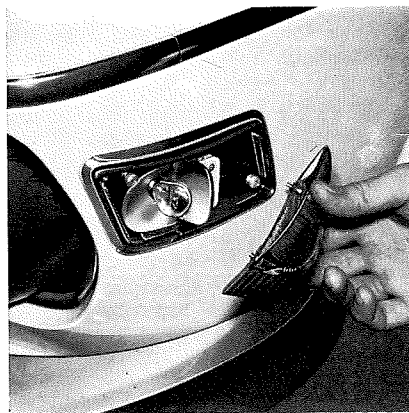

Rear lights

Open the luggage compartment, unscrew the two knurled nuts and take out the bulb holder. **Fig. 72**

Remove the defective bulb from its holder and insert the new bulb. Order of fitting from the outside inwards:

1. Turn indicator: spherical bulb (RL), 21 Watt,
2. Rear/parking/side light: spherical bulb (G), 5 Watt,
3. Stop light: spherical bulb (RL), 21 Watt,
4. Reversing light: spherical bulb (F), 21 Watt.

72

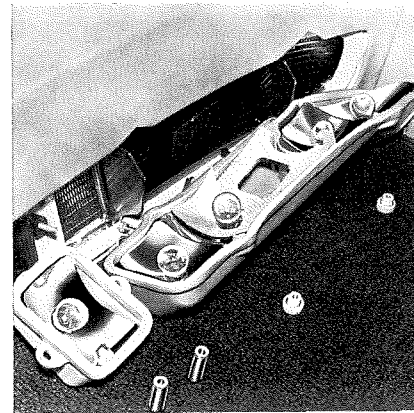

Rear fog warning light:

To change the bulb — festoon-type (K) 18 Watt — open the luggage compartment, unscrew the two knurled nuts and pull off bulb holder. Remove the defective bulb from the holder and insert the new bulb. **Fig. 72**

Licence plate light:

Loosen and remove the 2 Phillips head screws and take off the lens frame with rubber seal. **Fig. 73**. The contact clips for the 5 Watt (L) festoon-type bulb must grip the bulb end caps firmly and make good metal-to-metal contact. If necessary bend the clips carefully or clean the contact areas.

73

**Interior light:**

2 festoon-type bulbs (L), each of 5 Watt rating, are housed beneath the plastic dome. To change a bulb remove the chromium plated frame. **Fig. 74**

Luggage compartment lighting, engine compartment lighting:

Loosen and remove the 2 Phillips head screws, take off the plastic lens and change the 5 Watt (L) festoon-type bulb.

74

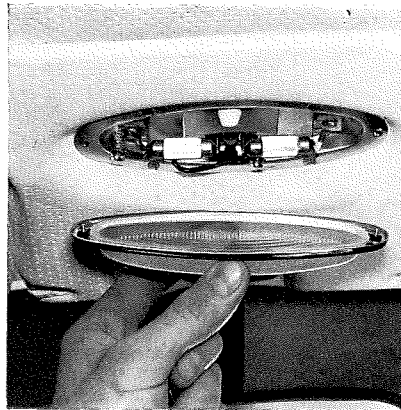

Correct headlight adjustment is of particular importance in today's traffic especially in view of safety requirements, and should therefore be carried out by a specialist workshop using the proper beam-setting equipment.

If this is not possible, open the engine compartment and reset the headlight beam by turning the two knurled plastic knobs as required. **Fig. 75**

1 = vertical adjustment
2 = horizontal adjustment

75

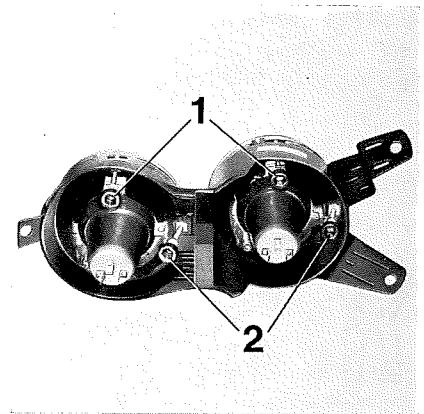

In the absence of an optical beam setting device, the procedure for aligning the headlights is as follows (**Fig. 76**). First check and adjust tyre pressures (see page 115). Position the car on a flat surface 16'6" (5 metres) from a light-coloured wall. Mark a point on the wall coinciding with the car's centre-line, and draw line «V-V» through this point. Load a weight of 155 lb (70 kg) in the middle of the rear seat, or get someone to sit in this position. Measure the height of the headlight centres from the ground, and mark line «h-h» horizontally on the wall at this height.

To adjust the two inner headlights (main beam):

Mark on the wall the distance of each headlight centre from the car's centre-line ($\frac{e'}{2}$), and erect vertical lines «a» and «b». Cover up the outer, dipped-

beam, headlights. The circle of maximum intensity of the headlight beams should be divided equally (i. e. symmetrically) by horizontal line «h-h» and vertical lines «a» or «b» respectively. Adjust the headlight beam by turning the knurled plastic knobs on the headlights. **Fig. 75**

The second main beam headlight is adjusted in the same way as the first.

To adjust the two outer headlights (dipped beam):

Now mark on the wall distances ($\frac{e'}{2}$) corresponding to the distance of each outer headlight centre from the car's centreline, and draw lines «a» and «b» at these points. A line «c» should be drawn 2" (5 cm) below, and parallel to, line «h-h».

Cover up one outer headlight, and set the other to the correct height by turning knob 1 (**Fig. 75**). The horizontal light/dark boundary on the left side must coincide with line «c».

Next, move the beam to left or right (knob 2, **Fig. 75**) until the junction between the horizontal part of the beam's upper boundary and the part inclined upwards at 15° coincides exactly with vertical line «a» or «b».

Repeat the process for the second outer headlight.

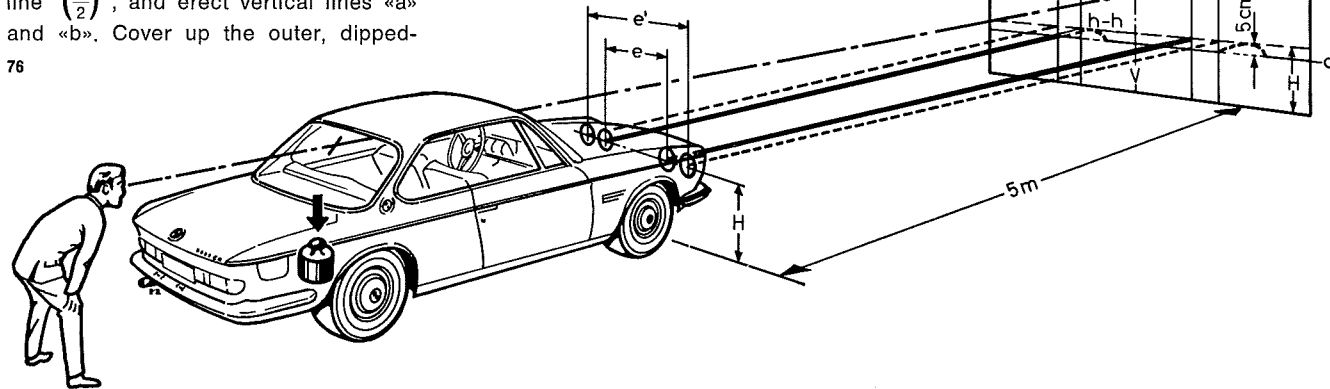

Headlights of the Sealed-Beam type (American system) should be adjusted as follows:

Use an optical or photoelectric beam-setting device, carrying out the adjustment in accordance with its maker's instructions. Only if a suitable device is not available, position the car on a flat surface at 25' (7.6 meters) from a light-colored wall. Adjust tire pressures to the specified levels, and load the car with 155 lbs (70 kg) or the weight of one person in the center of the front seats.

Mark lines «V-V», «h-h» as well as «a, a'» and «b, b'» (the two latter pairs corresponding to distances $\left(\frac{e}{2}\right)$ and $\left(\frac{e'}{2}\right)$ of the headlight centers from the car's centerline) as described on the preceding page.

To adjust the two inner headlights (high beam):

77

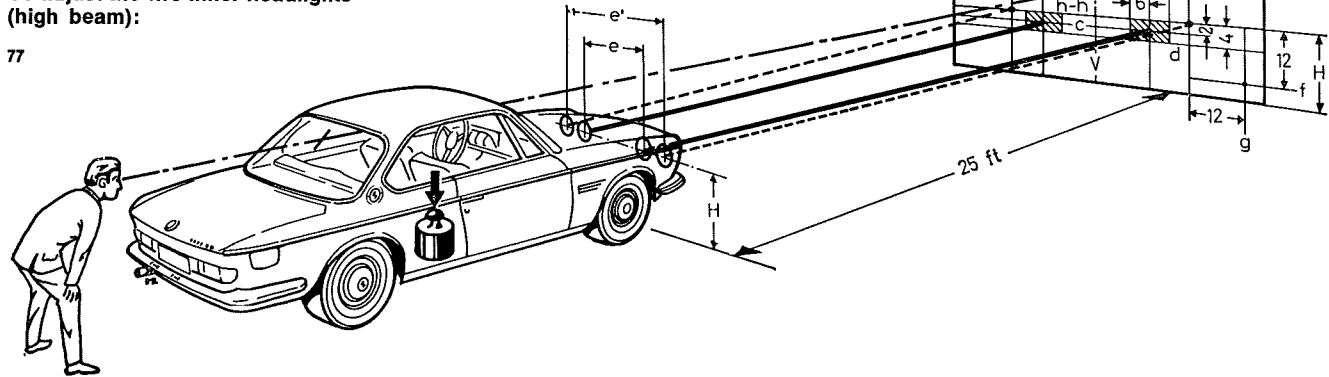

Mark two lines «c» and «d» 2" (5 cm) and 4" (10 cm) below, and parallel to, horizontal line «h-h».

Draw additional vertical lines 6" (15 cm) to the left and right of lines «a» and «b».

Fig. 77

Cover up the low beam headlights. Each high beam is correctly aimed when the center of the circle of maximum intensity coincides with the lines intersecting within the rectangle shown shaded in the diagram, or at least falls somewhere within the rectangle.

Repeat the adjustment for the second high beam headlight. To move the beam up and down or from side to side, turn the appropriate knurled plastic knob on the high beam headlight housing (see Fig. 75).

To adjust the two outer headlights (low beam):

With the headlights switched to **low beam**, adjust until the circle of maximum intensity is intersected equally (i. e. symmetrically) by lines «f» and «g» 12" (30 cm) below horizontal line «h-h» and at the same distance to the right of vertical line «a'» or «b'» respectively. Adjust with the two knurled plastic knobs on the outer headlight units.

Fig. 75

The second outer headlight should be adjusted in the same way as the first.

Care and maintenance

Your brand-new car certainly is a fine sight. How long it continues to appear so attractive depends on the care with which you look after it.

Wash the car away from direct sunlight and when the engine compartment lid has cooled, to avoid the formation of patches.

Road dust and dirt contain many chemicals which will in the long run damage your car's paintwork. For this reason any car — especially a new one — should be washed as often as possible.

Tar stains, dead insects and minor paintwork damage should be removed or touched up without delay, or else the paint may discolour or patches of rust appear.

Clean the car's interior with a brush and pan or vacuum cleaner.

The fitted carpets can be removed from the car for easier cleaning if the fastenings are pulled away. **Fig. 78**

Soften dirt on the paintwork with a fine spray of water, then rinse away.

Do not spray water into the fresh air inlet grilles in front of the windscreen, the openings on the rear roof pillars or the gap formed where the luggage compartment lid pivots.

After rinsing down, wash the upper part of the body, beginning with the roof, with lukewarm water, using a sponge or special glove. Rinse the sponge or glove in clean water at frequent intervals.

Clean the lower parts of the body and wheels last of all, and if possible keep a separate sponge just for these areas. After washing down, spray thoroughly once again and dry with a clean wash leather to prevent water droplets from forming patches.

If cleaning the car with water alone is insufficient, use a branded car shampoo in the concentration recommended by the makers. Rinse down afterwards with a generous stream of water.

78

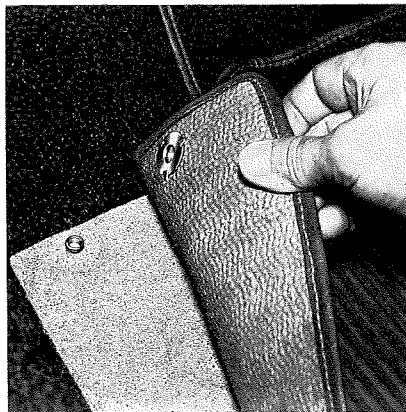

Too frequent use of car shampoos will remove fatty substances from the paint, which will become brittle, necessitating in turn treatment with a branded paint preservative.

Your car's paintwork needs polishing or preserving when water no longer forms round droplets on the surface. Use only branded car care products in accordance with the instructions supplied with each product.

Minor paint blemishes can be touched up with a BMW paint spray aerosol or touch-up paint stick. The colour you need is indicated on the plate attached to the front pillar of the driver's door. **Fig. 79**

79



The special preservation of **cavities** and the **car's underside**, provided as standard by the factory, must be renewed at the latest 8 months after registration and then every 12 months (see page 42).

No mineral oils, spray or other preservative substances should be allowed to reach the wheel cylinder piston sealing sleeves or the discs themselves.

Clean **chromium plated or polished components** with water or soap and water. A branded chromium preservative should be applied afterwards.

Tar stains should never be scraped off with a knife or hard object. Use a tar remover recommended by the factory. Your BMW Service depot will supply you with the recommended brands.

Rubber components should be treated only with pure water or glycerin.

Clean the **wiper blades** with soapy water. Renew the blades at least once a year.

Stains on cloth upholstery can be taken out with ordinary stain remover, but do not let any such product come into contact with real or artificial leather.

Real and artificial leather should be wiped down with a damp cloth and dried immediately afterwards.

When you took delivery of your car you received a **Service Booklet** made out in your name and for your own particular vehicle. After the **free pre-delivery** check, your BMW service station removed the corresponding section from the booklet and made an entry to confirm that the work had been properly carried out. The same procedure will be followed when it is time for the 1st BMW Program Test at approx. 600 miles (1000 km).

Then your BMW service station will attach a self-adhesive label to the driver's door post (**Fig. 80**) as a reminder of when the next service is due.

80

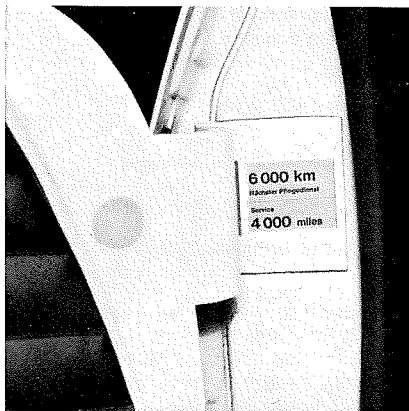

This and all other servicing or BMW Program Tests will be confirmed by entries in the appropriate spaces of the Service Booklet.

Please ensure that the entries are correct; in the event of a warranty claim this evidence will be needed, and you will in any case be glad of proof at a later date that the car has been well cared for.

We recommend that the prescribed BMW Program Test or service work be carried out **regularly** by a BMW service station. This is the only way to guarantee that all operations are based on the latest factory recommendations. A list of workshops in the world-wide BMW network of authorised dealers and service stations is supplied with the car, so that you can be sure of reliable attention for your car wherever you may travel.

In the interests of your car's reliability and extended operating life, we recommend that **at least two BMW Program Tests per year** be carried out, even if the distance covered is less than the prescribed figure.

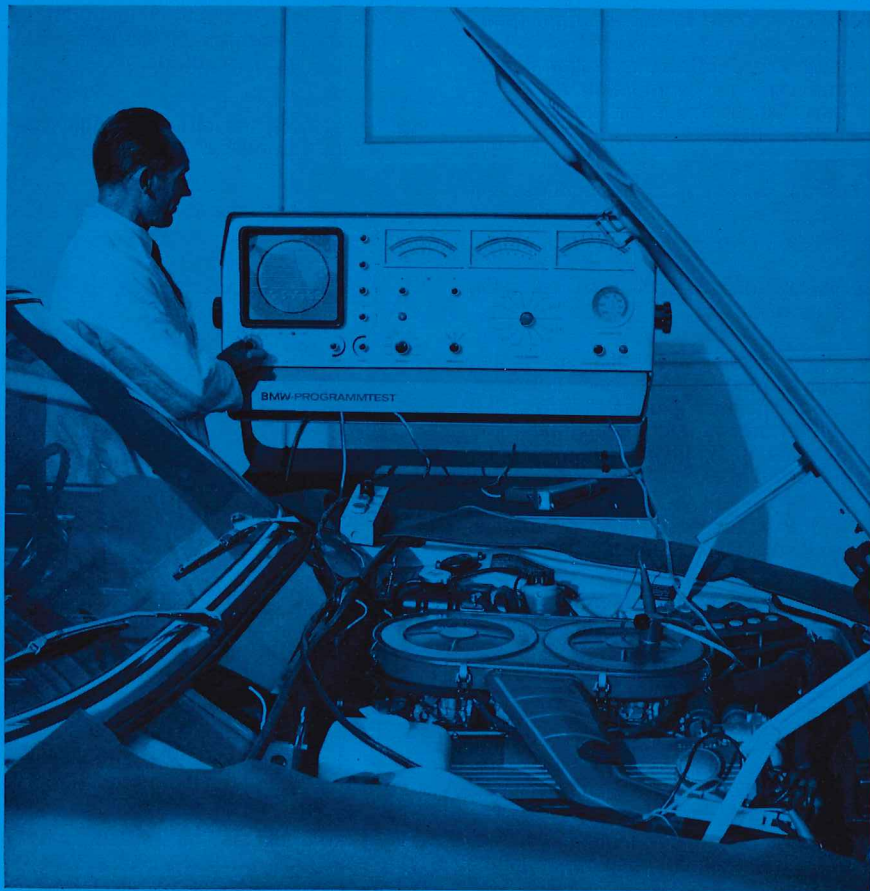

Testing, checking, adjusting...

... is essential from time to time. At a BMW Service Station it is performed according to the same high standards used at the factory itself. The operators of these service establishments have installed the most modern equipment to maintain YOUR BMW Coupé, for example engine testers like the one shown here. Preventive action + precision = reliability.

1st BMW Program Test

after 600 miles (1000 km)

1. Change engine oil while at normal operating temperature. Renew oil filter element.
2. Change gearbox oil while at normal operating temperature (not on Automatic models).
3. Change oil in final drive while at normal operating temperature
4. Rear axle halfshafts: check bellows for leaks.
5. Hydraulic power steering: check for leaks, check oil level in reservoir, top up if required.
6. Check coolant level and top up if required.
7. Check brake system lines and connections for leaks, damage or distortion. Check fluid level in reservoir and top up if required.
8. Clean mesh filter in fuel pump. Tighten bolts on fuel pump (BMW 3.0 CS).
9. Tighten nuts and bolts on carburetors.
10. Apply grease on the bearing points and moving parts of the throttle butterfly lever. Tighten fastening clamps and bolts on the injection valve support. Check pipes for correct position and leaks.
11. Check correct operation and freedom of movement of flap for automatic intake air preheat.
12. Check V-belt tension and retension if required.
13. Tighten nuts and bolts on engine (see Specifications for tightening torques): this includes right and left rubber engine mountings, intake and exhaust manifolds, oil sump, cylinder head studs.
14. Check valve operating clearances and adjust as required.
15. Tighten following nuts and bolts (see Specifications for tightening torques): front axle, steering, gearbox, propeller shaft, halfshafts, rear axle and brakes, wheel nuts.
16. Tighten nuts and bolts on front and rear lids, hinges and locks, door locks, strikers and exhaust system.
17. Check steering for absence of play in straight-ahead position; adjust if required.
18. Check foot brake and bleed brake system if required. Check handbrake and adjust if required.
19. Check front wheel bearing play and adjust if required.
20. Check front wheel toe-in and adjust if required.
21. Check tyre pressures and correct if required.
22. Check lighting, instrument readings, horns, controls and rear view mirrors.
23. Check headlight beam settings and adjust if required.
24. Carry out the prescribed engine test with a BMW Program Tester. Check engine idling speed and adjust if required (using a Synchrotest device; BMW 3.0 CS).
25. Final inspection of items affecting road safety (brakes, steering, clutch or automatic transmission).

Note: Road wheels can be balanced on request, the work being charged separately.

Service

every 8000 miles (12 000 km), beginning at 4000 miles (6000 km) speedometer reading.

1. Change oil in engine and filter while at normal operating temperature. Renew oil filter element.
2. Check coolant level and top up if required.
3. Check oil level in reservoir of hydraulic power steering.
4. Check battery acid level and add distilled water if required.
5. Check level of brake fluid in equalizing reservoir.
6. Check tyre pressure and adjust if necessary.
7. Check wheel nuts on light-alloy wheels for prescribed torque and tighten if required.
8. Fill the screenwasher tank.
9. Check lighting, instrument readings, horns, controls and rear view mirrors.
10. Final inspection of items affecting road safety (brakes, steering, clutch or automatic transmission).

Tighten cylinder head studs at the first service at 4000 miles (6000 km) speedometer reading (see Specifications for tightening torques).

Note: Measure total thickness of brake pads with linings if the brakes have been subject to excessive use (to be invoiced separately).

BMW Program Test

every 8000 miles (12 000 km), beginning at 8000 miles (12 000 km) speedometer reading.

1. Install new spark plugs.
2. Install new contact breaker points. Apply a wedge-shaped area of Bosch Ft 1v4 grease to the distributor hammer slide. Add 2 drops of oil to the felt pad in the distributor shaft.
3. Change oil in engine and filter while at normal operating temperature. Renew filter element.
4. Check oil level in gearbox and top up if required (change the oil only while at normal operating temperature): manual gearbox every 22 000 miles (36 000 km).
5. Check oil level in final drive and top up if necessary.
6. Halfshafts: check bellows for leaks.
7. Check hydraulic power steering for leaks, check oil level in reservoir and top up if required.
8. Check coolant level and top up if required.

9. Check battery acid level, and top up if required with distilled water.
 10. Check brake fluid level in reservoir and top up if required.
 11. Apply grease on the bearing points and moving parts of the throttle butterfly lever.
 12. Check flap of automatic intake air preheat for freedom of movement and correct operation.
 13. Check V-belt tension and retension if required.
 14. Oil carburettor linkage joints and pivots.
 15. Tighten nuts on exhaust manifold (see Specifications for tightening torques).
Visual inspection of rubber engine mountings left and right, intake, carburettor, and fuel pump mountings.
 16. Check valve operating clearances and adjust if required.
 17. Intake air silencer: renew filter element (BMW 3.0 CSI) or elements (BMW 3.0 CS). Reduce this interval for renewing the element(s) in dusty conditions.
 18. Check steering for absence of play in straight-ahead position and adjust if required. Examine track rods and universal joints for wear.
 19. Adjust the brake bands on the automatic transmission every 16000 miles.
 20. Propeller and halfshafts: check conditions of joints and rubber coupling.
 21. Disc brakes: check total thickness of pads and linings and examine surface condition of discs. Renew pads if required.
 22. Tighten nuts and bolts as follows (see Specifications for tightening torques): steering box mounting, brake caliper mountings.
 23. Front wheel bearings: check play and adjust if required.
 24. Check tyre pressures and correct if required. Check condition of tyres. If wear is uneven, optional optical alignment and correction of wheel positioning (invoiced separately).
 25. Check brake lines and connections for leaks, damage or distortion. Check handbrake cables for freedom of movement. Adjust handbrake.
 26. Tighten bolts and nuts on door locks and strikers.
 27. Oil door and front lid hinges, grease front and rear lid locks, door lock catches and strikers. Check operation of these components.
 28. Carry out the prescribed engine test with the BMW Program Tester. Check engine idling speed and adjust if required (use the Synchro-tester for the BMW 3.0 CS).
 29. Final inspection of items affecting road safety (brakes, steering, clutch or automatic transmission, headlight beam settings, lighting, instrument readings, horns, controls and rear view mirrors).
- Note:** If desired, interchange the road wheels in the prescribed pattern and rebalance.
- Every 40 000 miles (60 000 km) (to be invoiced separately):
- Hydraulic power steering: check for correct operation and renew filter.
- Clean fine-mesh filter in the fuel pump and pre-filter in the induction unit. Renew main fuel filter and air filter element at auxiliary air fan. Renew slide — in contact plate in distributor.
- Tighten nuts and bolts as follows (see Specifications for tightening torques):
- rubber engine mountings left and right, intake carburettor, fuel pump, and exhaust mountings.
- Check clutch drive plate for wear.

Description of maintenance routines

Engine oil

Frequency of oil changes	Outside temperature	Oil grades	
Every 4000 miles (6000 km) or every 6 months at the latest, for every season of the year.	Usually above 86° F (30° C)	Branded 4-stroke HD oil single grade oil preferably	
	The whole year above 14° F (-10° C)	SAE 40	SAE 20 W 50
	Usually below 50° F (10° C)	SAE 30	SAE 20 W 40 SAE 20 W 50
		SAE 20	SAE 10 W 30 SAE 10 W 40 SAE 10 W 50

Total oil capacity: 8.8 Imp. pints/5.3 US quarts/5 litres + 1.3 Imp. pints/0.8 US quarts/0.75 litres if the filter is also changed.

Oil level: Fill to the upper mark on the dipstick, never higher.

Changing engine oil:

Remove drain plug (19 mm spanner) on the bottom right of the sump. Replace and screw up firmly after the old oil has drained away fully. **Fig. 81**

81

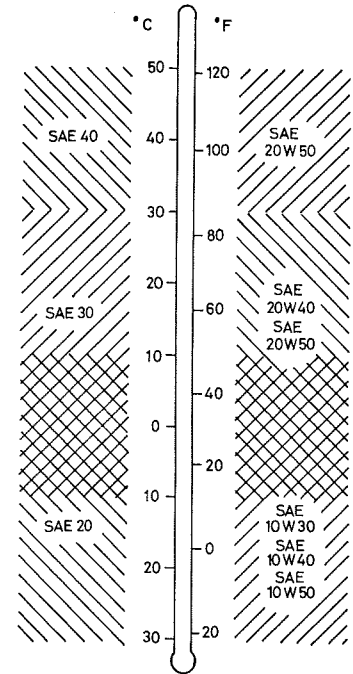
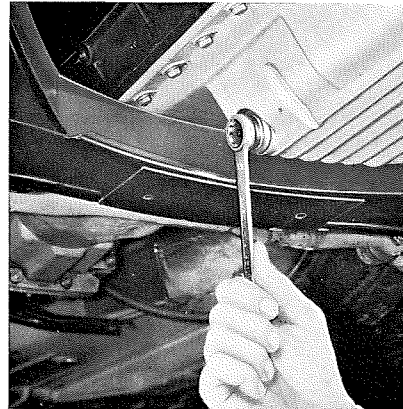

Oil filter element: Renew every 4000 miles (6000 km) when the engine oil is changed:

Remove front panel protection; do not forget to replace after changing filter.

Unscrew the clamping bolt (17 mm spanner) and remove it with sealing ring and outer cover, leaving the upper part of the filter in place.

Clean out the filter housing, renew the element and reassemble with a sealing ring in good condition. **Fig. 82**

82

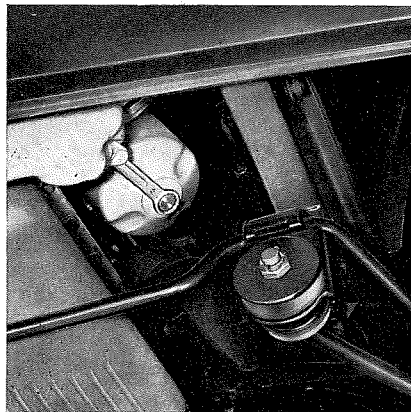

Change the oil in the manual gearbox only while at normal operating temperature, every 22 000 miles (36 000 km): Remove oil drain plug (17 mm intl. hex) then oil filler plug (17 mm intl. hex) on the left of the gearbox housing. This will help the oil to drain more rapidly. When fully drained replace the drain plug (screw on firmly). Both plugs have conical threads and may not be replaced with plugs having metric threads. **Fig. 83**

Total oil capacity: 1.9 Imp. pints/1.2 US quarts/1.1 litres.

Oil level: up to underside of filler orifice
Oil grade: Branded SAE 80 gearbox oil (not hypoid gear oil); in an emergency, HD engine oil.

83

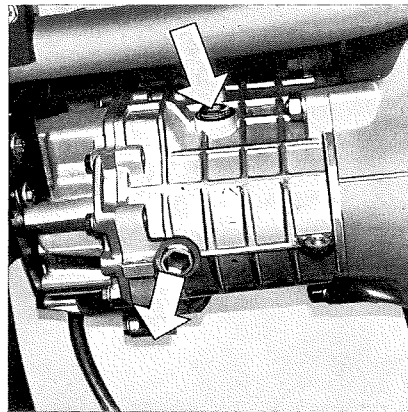

To check oil level in the automatic transmission:

Park the car on a flat level surface, apply the handbrake and run the engine at normal operating temperature with the selector lever in the «P» or «0» position, at idling speed.

Remove the transmission oil dipstick, **Fig. 84** (see page 38), wipe with a **non-fluffy** cloth, re-insert and measure oil level. This must lie between the appropriate marks according to the temperature, cold or warm. The quantity of oil represented by the space between the two marks is approx. 1.1 Imp. pints/0.6 US quarts/0.6 litres.

It is not necessary to **change the oil** in the **automatic transmission**.

84

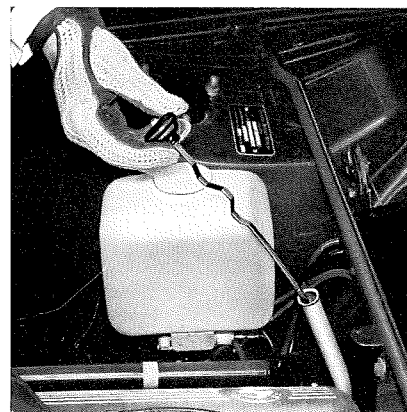

Change the oil in the final drive while at normal operating temperature at 600 miles (1000 km):

Remove the oil drain plug (10 mm Allen key), then the filler plug (10 mm Allen key) on the right hand side of the final drive casing. This will assist the oil in draining more rapidly. Clean the drain plug and replace, screwing in firmly. **Fig. 85**

Total oil capacity: 2.6 Imp. pints/1.6 US quarts/1.5 litres.

Oil level: up to lower edge of filler orifice. Check every 8000 miles (12 000 km).
Oil grades: Branded SAE 90 hypoid

gear oil, running-in grade (your BMW service station knows the factory-approved grades).

Check oil level in hydraulic power steering whenever engine oil is checked or routine maintenance work carried out. With the **engine stopped**, unscrew the wingnut and take off the reservoir cover. The oil level should be approx. 0.2" (5 mm) above the mark on the side of the reservoir. Top up if necessary (for oil grades, see page 107). Next, **start the engine** and add more oil if required until the level stabilizes at the mark on the reservoir wall (**Fig. 86**). Then stop the engine: the oil level should rise to a final position approx. 0.2" (5 mm) above the

mark. Replace the cover and tighten the wingnut. Check that the cover is in position properly and that the steering box has no leaks. All other work on the hydraulic power steering — including filter renewal and checking for correct operation — should always be entrusted to a BMW service station.

The **wheel bearings** should be serviced only by an authorized BMW service station; every 40 000 miles (60 000 km) they should be examined and fresh grease added if required. **Fig. 87**

Wheel bearing grease: Shell Darina II grease, drip point over 500° F (260° C).

85

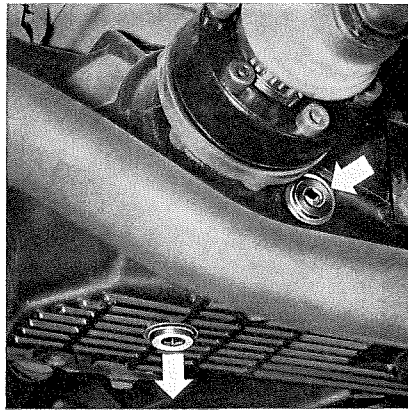

86

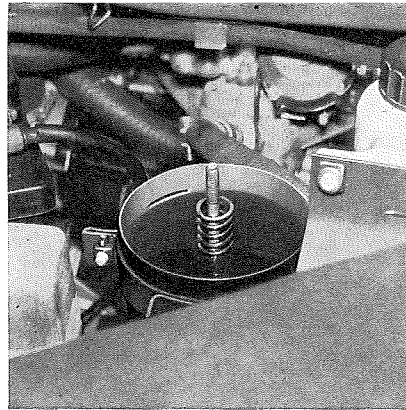

87

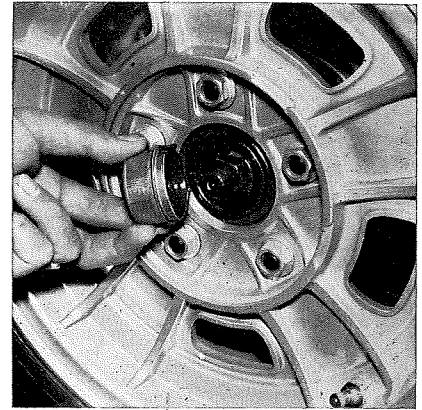

Lubricate the distributor during a BMW Program Test every 8000 miles (12 000 km):

Apply a narrow wedge-shaped area of Bosch Ft 1v4 grease to the **fibre heel** of the distributor arm on the side nearest to the arm bearing. **Fig. 88, 1**

Take off the distributor rotor and allow 2 drops of engine oil to soak into the **felt pad within** the distributor shaft. **Fig. 88,2**

Warning: No oil must overflow or reach the contact breaker points. Excess oil in the distributor can lead to misfiring. Oil vapour within the distributor casing causes rapid points wear.

88



The transparent **brake and clutch fluid reservoir** is located in the engine compartment on the left hand side, and the fluid level can be inspected from the outside of the reservoir. **Fig. 89**

If the fluid level should fall too low, an electrical contact on the reservoir operates the red telltale lamp in the revolution counter.

Brake fluid is hygroscopic (moisture absorbent), and becomes contaminated in the course of time with moisture from the atmosphere. To ensure that the brakes remain fully operational, it is **absolutely necessary for the brake fluid to be renewed once a year** in the course of a BMW Service.

89

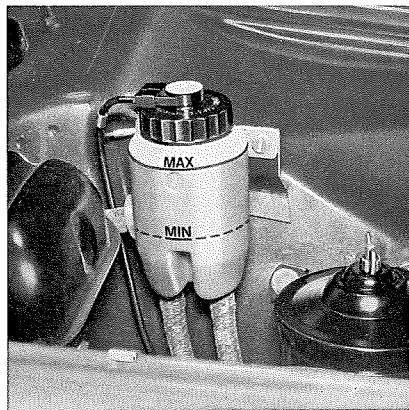

Capacity: up to the «Max.» marking. The amount of brake fluid between the two marks is approx. 0.44 Imp. pints/0.3 US quarts/0.25 litres. **Fig. 89**

Grade: ATE blue brake fluid «S».
CASTROL disc brake fluid
CASTROL **girling** brake fluid green

The **clutch** requires **no maintenance**, and wear is automatically taken up at the slave cylinder. Every 40 000 miles (60 000 km), during a BMW Program Test, clutch driving disc wear should be checked in situ.

Press the withdrawal arm by hand in the direction of travel until the limit of movement of the slave cylinder is reached. When new, total travel A at the thrust rod is 0.67-0.75" (17-19 mm). **Fig. 90**

90

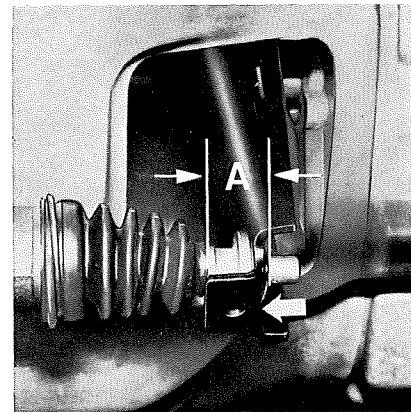

As the driving plate wears, distance A will become smaller. When the wear limit will become smaller. When the wear limit ($A = 0.2''/5 \text{ mm}$) is reached, the clutch driving plate should be renewed by a BMW service station.

Loss of liquid from the hydraulic clutch mechanism, or the presence of air in the system, can lead to incomplete clutch withdrawal and damage to the transmission.

Bleed the system in good time, using the bleed screw provided.

Fig. 91

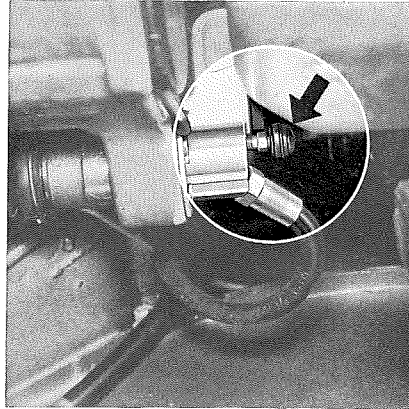

In the interests of even tyre wear, ask for the **road wheels** to be interchanged every 8000 miles (12 000 km) during a BMW Program Test. The front and rear wheels on either side of the car should be changed round — never move a wheel from one side of the car to the other like an X. If need be, the spare wheel can be included in the interchange pattern. **Fig. 92**

All 4 road wheels should be **rebalanced** statically and dynamically, if possible on the car and during a BMW Program Test every 8000 miles (12 000 km).

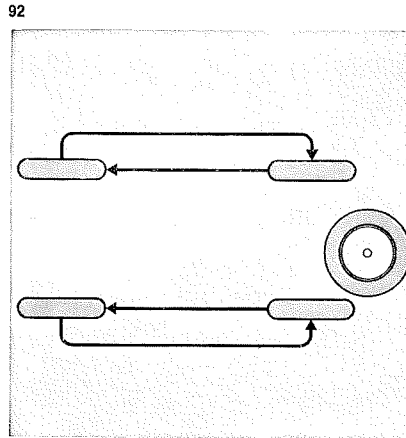

If routine inspection of the tyres reveals wear, damage, penetration of foreign bodies or similar, or a seriously uneven wear pattern, we recommend that the wheel alignment be checked by a specialist workshop as soon as possible, the car being loaded with the prescribed weight at the time.

Every 4000 miles (6000 km), or at least once a month, the **battery acid level** should be checked. Remove the battery cover and unscrew the 6 plugs on top of the casing. The acid level should be approx. 0.2" (5 mm) above the top surface of the plates in each cell, or up to the level mark visible in the plug orifice. If the acid level is too low, top up with distilled water (not acid). **Fig. 93**

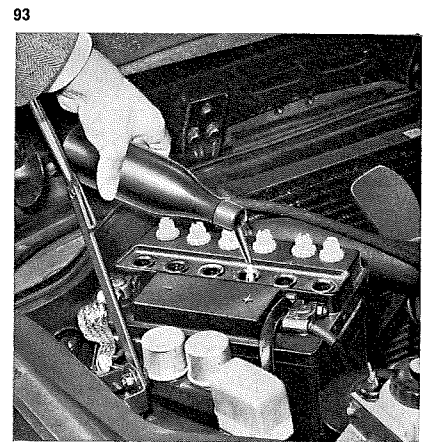

The upper part of the battery should be kept clean and dry.

Warning: Do not allow acid or lead oxide from the terminals to contact clothing. Do not bring a naked light near the battery – there is a risk of explosion.

To remove and replace the battery, unscrew or screw up the toggle screw with holding rail. **Fig. 94**

94

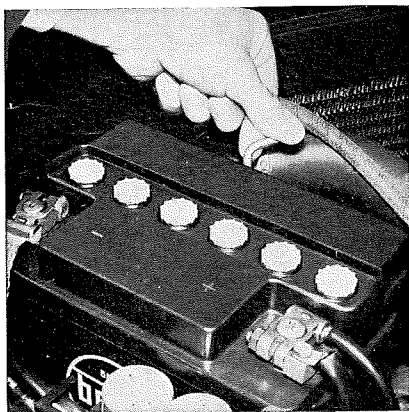

In addition to routine inspection of coolant level, antifreeze, hoses and hose clips, we recommend that **every two years** the complete contents of the cooling system be renewed (see page 41). The radiator filler cap should also be inspected for leaks, and the pressure relief and vacuum valves checked.

The **capacity of the cooling system** including heater is 21.1 Imp. pints/25.4 US pints/12 litres. **To drain coolant** from the system:

1. Detach front panel lower protective apron; do not forget to replace after draining coolant.
2. Loosen and remove the hexagon bolt at the lower right hand side of the radiator (11 mm spanner). **Fig. 95**

95

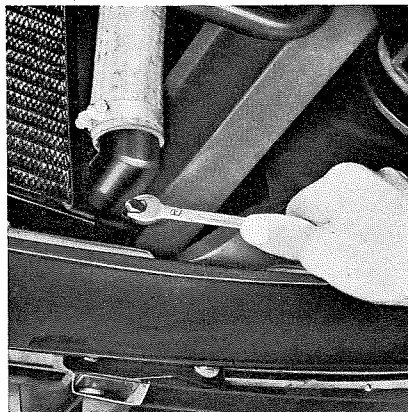

3. Remove the hexagon bolt on the rear right hand side of the engine block (19 mm spanner). **Fig. 96**

96

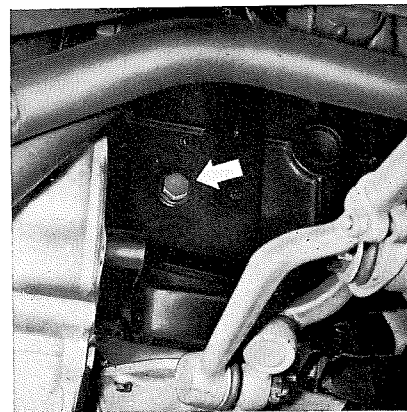

Initial filling of cooling system: Loosen the bleed screw in the coolant distributor flange; add coolant by way of the equalizing reservoir until it emerges free from bubbles at the bleed slot. Then retighten the bleed screw firmly. **Fig. 97**

Close the radiator cap by turning as far as the second stop. Drive the car or run the engine until the normal operating temperature is reached.

Turn back the filler cap to the first stop to allow air to escape from the cooling system, then remove. Top up coolant to max. «a» = 2 cm (0.8 ins.) above the base of the equalizing tank opening if the engine is at normal operating temperature, or «a» = 3.5 cm (1.4 ins.) if cold. Then screw on the cap to seal the tank. Overfilling will only dilute the coolant, since it will escape through the overflow pipe. **Fig. 98**

Remove the **air filter elements (or element) in the intake air silencer** every 4000 miles (6000 km) and inspect for cleanliness. Dust and dirt clinging to the elements can be removed by knocking carefully and blowing through from the inside; if more severely clogged, and in any case after 8000 miles (12 000 km) during a BMW Program Test, the elements should be renewed.

BMW 3.0 CS

To remove, lift up the over-centre catches, take off cover and take out elements. **Fig. 99**

97

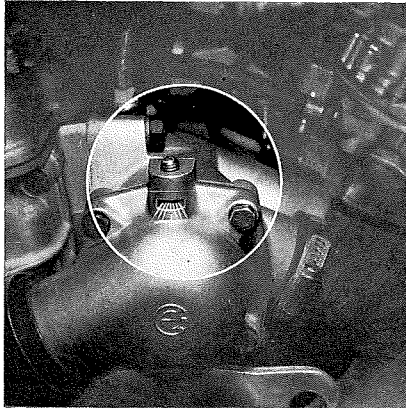

98

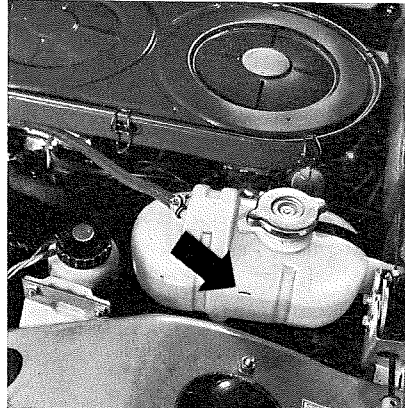

99

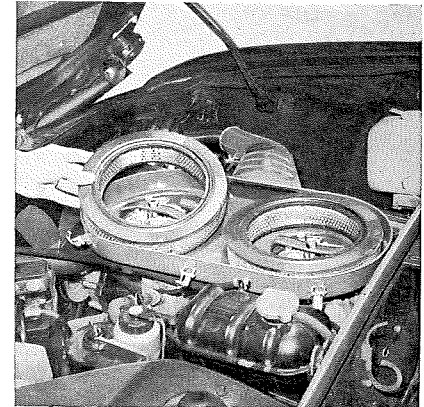

Clogged air filter elements increase fuel consumption and prevent full engine power from being developed.

BMW 3.0 CSI

To remove, lift up the over-centre catches, take off cover and take out element. **Fig. 100**

The fine mesh filter in the fuel pump of the BMW 3.0 CS should be cleaned every 40 000 miles (60 000 km); remove the threaded plug (13 mm spanner) with sealing ring to gain access to the filter. **Fig. 101**

Remove the mesh filter and wash out in clean petrol. When replacing, do not use the same sealing ring unless in perfect condition. Tighten the 6 cheese-head bolts on the fuel pump evenly with a screwdriver.

Fuel filters BMW 3.0 CSI

The fine mesh filters in the fuel supply system should be cleaned every 40 000 miles (60 000 km) and the full-flow filter renewed.

Renewing full-flow filter:

1. Loosen fastening clamps on fuel hoses and filter.
2. Pull off hoses and renew complete filter. **Fig. 102**

Important: Note the direction of flow shown on the filter label when fitting in a new filter.

100



101

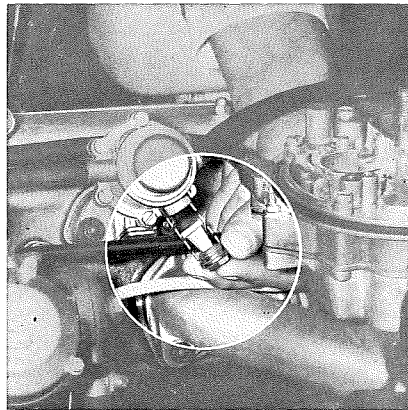

102

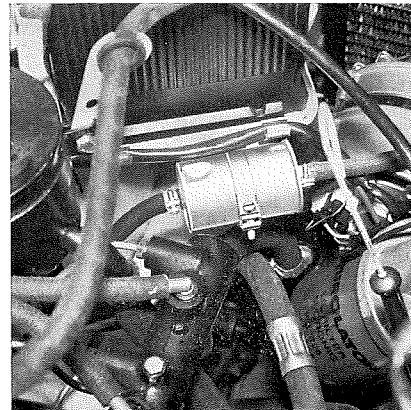

Fine mesh filter in the fuel supply pump:

1. Loosen fastening clamp on intake hose. Pull hose off supply pump and seal. **Fig. 103,1**
2. Remove fine mesh filter (bag-type) from connection manifold. **Fig. 103,2**
3. Clean fine mesh filter.

103

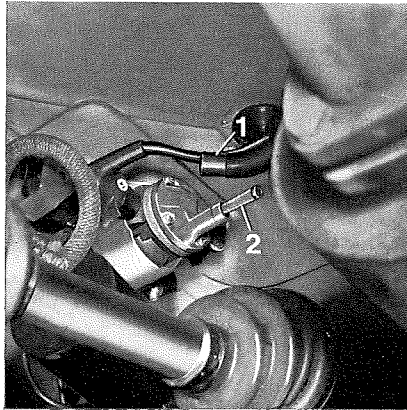
**Fine mesh filter in the intake unit in the fuel tank:**

1. Remove right hand floor panel in luggage compartment.
2. Loosen fastening clamp on intake hose and pull hoses off intake unit.
3. Turn intake unit counter-clockwise by means of suitable tool (screwdriver used as a lever) – bayonet catch – and pull out.
4. Clean fine mesh filter. **Fig. 104**

Important: Use new sealing ring when replacing.

104

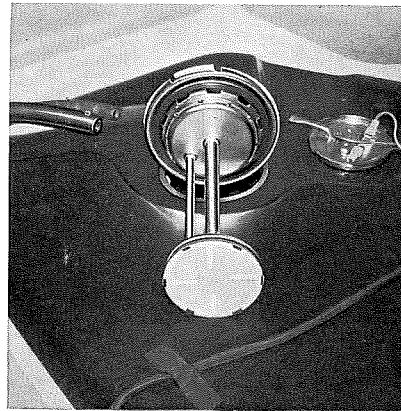
**Check spark plug electrode gaps:**

Before new spark plugs are fitted their gaps should always be checked with a feeler gauge, and the earth electrode bent if necessary to achieve the prescribed gap «a» of 0.24 ± 0.004 " (0.6 ± 0.1 mm) **Fig. 105**

Coat the threads of the spark plugs before insertion with a bit of graphite grease.

Renew spark plugs every 8000 miles (12000 km) during a BMW Program Test.

Details of the correct spark plugs are given on the inside back cover.

105

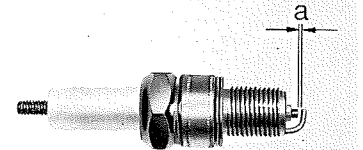

Renew the contact breaker points every 8000 miles (12 000 km) during a BMW Program Test.

The dwell angle should be set to 35° to 41° (BMW 3.0 CS) or 39° to 45° (BMW 3.0 CSi) by means of the BMW Program Tester (dwell angle measuring unit).

If no dwell angle tester is available in an emergency, adjust points gap as follows: Turn the engine over until the distributor arm is fully raised (fibre heel on peak of distributor shaft cam).

Loosen locking screw «a» somewhat, insert a screwdriver blade between the two small pegs «b» and into slot «c» on the points, and turn gently until the points gap, measured with a feeler gauge, is 0.014–0.016 ins. (0.35–0.40 mm). Tighten screw «a» and check that the points gap has not altered. **Figs. 106 and 107**

Checking ignition timing: this must always be done after the points gap has been reset, or every 8000 miles (12 000 km) during a BMW Program Test. Adjust by the dynamic method, with vacuum advance inoperative, using a stroboscopic light gun and revolution counter.

Adjusting speed:

BMW 3.0 CS: 1700 rpm
BMW 3.0 CSi: 2500 rpm

The timing mark «Z» (a pressed-in steel ball, on Automatic models a long taper peg on the side of the starter ring) for No. 1 cylinder is located on the flywheel, and can be inspected through a sight hole on the left hand side, below the starter motor. **Fig. 108**

Ignition timing should only be checked or adjusted by a BMW service station.

106

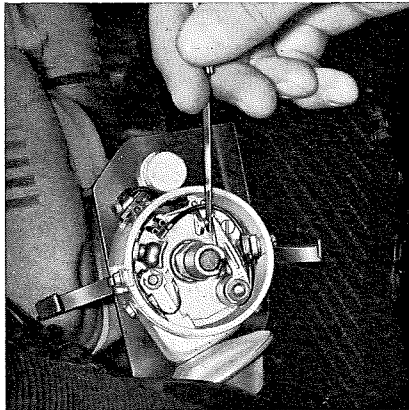

107

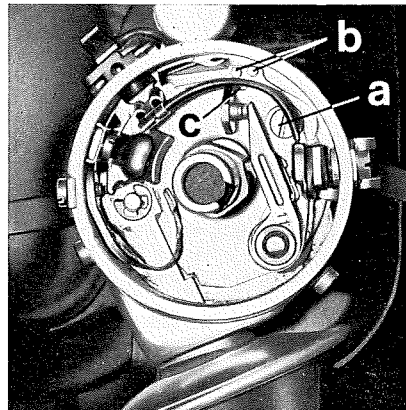

108

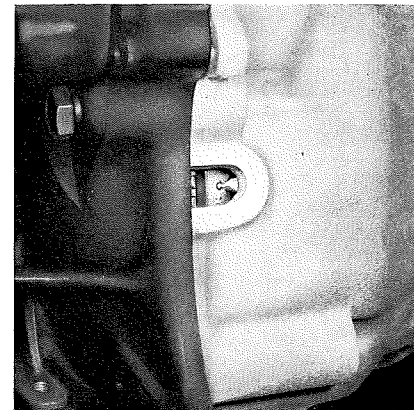

Release contacts — distributor BMW 3.0 CSI

Renew contact end every 40 000 miles (60 000 km). The two release contacts are fitted on the contact end in the bottom part of the distributor. It is not necessary to remove the distributor for renewing the contact end. Just unscrew the fastening bolts at the side and pull off triple plug. **Fig. 109**

Do **not** apply grease on the baffle heads of the contact end, as these heads are lubricated by the felt pad on the distributor shaft which is coated with grease at the factory.

109

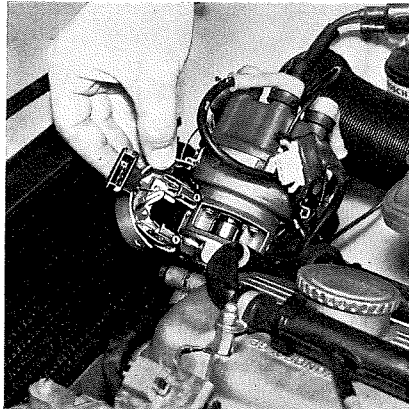

Check valve clearance and adjust if required every 8000 miles (12 000 km) during a BMW Program Test with the engine stopped and cold or at max. 95°F (35°C) coolant temperature.

BMW 3.0 CS

Open the air silencer by releasing the catches, and remove the filter elements. Unscrew the nuts (17 mm spanner) securing the intake silencer, pull off the preheat and engine breather hoses and remove the intake silencer body. **Fig. 110**

110

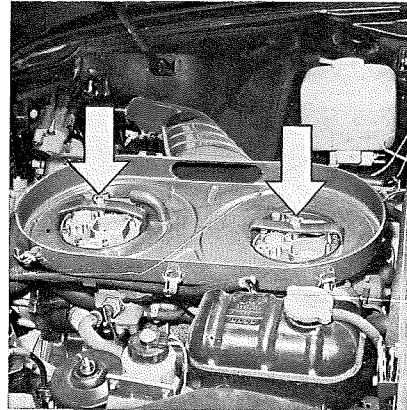

BMW 3.0 CSI

Disconnect the hoses on the air silencer and remove silencer from holder. **Fig. 111**

111

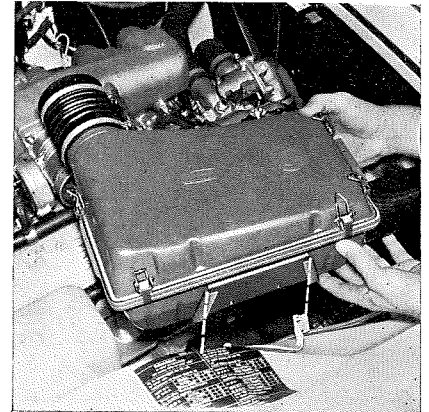

Remove the cylinder head (10 mm cap nuts with washers).

During the initial BMW Program Test after 600 miles (1000 km), and again at the 4000 miles (6000 km) Service, the **cylinder head studs** should be tightened to remove slack, working in the prescribed sequence (**Fig. 112**) and to the specified torque (see Specifications). The prescribed valve clearance of 0.01–0.012 ins (0.25–0.30 mm) for both inlet and exhaust valves should be measured with a feeler gauge between the valve and the rocker in accordance with the **firing order 1–5–3–6–2–4**, with the cylinder being checked or adjusted at TDC on its compression stroke.

112

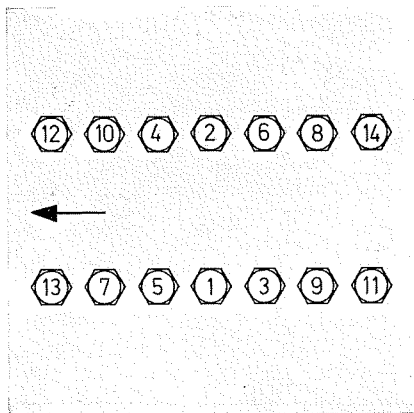

TDC on the compression stroke is reached for each cylinder when the valves of the corresponding cylinder on the other side of an imaginary line dividing the engine between No. 3 and No. 4 cylinder are on the overlap:

TDC Cyl. No.	Overlap Cyl. No.
1	6
5	2
3	4
6	1
2	5
4	3

To adjust valve clearance at the rocker, loosen the hexagon nut (10 mm spanner). **Fig. 113**

113

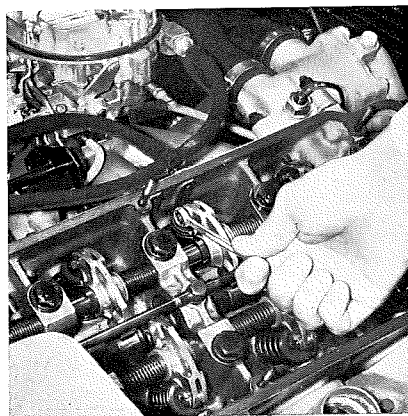

Turn the eccentric adjuster with the drift provided (see toolkit) until the prescribed clearance is obtained. **Fig. 114**

Tighten the hexagon nut and check that valve clearance has not altered.

114

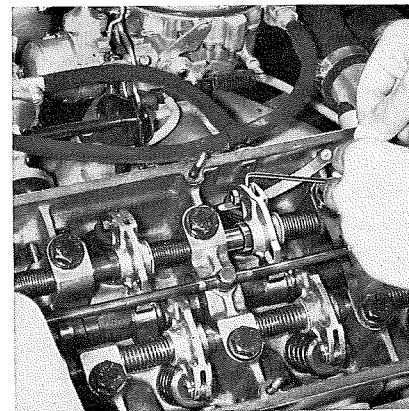

BMW 3.0 CS

Reconnect the intake air preheat and engine breather hoses. Place the intake air silencer body in position and secure. **Fig. 115**

115

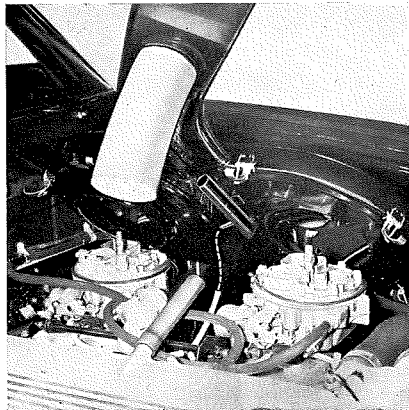
**BMW 3.0 CSI**

Place intake air silencer body in holder and reconnect hoses. **Fig. 116**

116

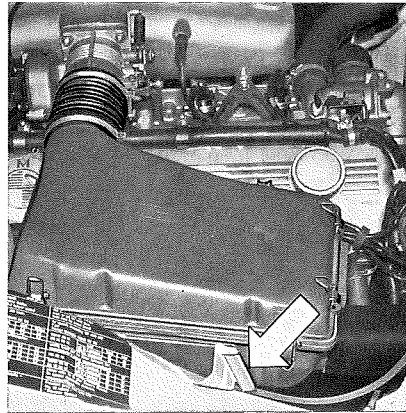
**BMW 3.0 CS**

The flap for the **automatic intake air preheat** device is mounted in the intake air silencer pipe, and is opened and closed by a temperature-sensitive expanding element. Every 8000 miles (12000 km), during a BMW Program Test, check the flap for correct functioning and freedom of movement, and oil the pivots if necessary. When the flap is closed, the engine is supplied with air pre-heated in the exhaust manifold. As the outside temperature rises to above approx. 77° F (25° C), the flap opens and blocks off the preheat passage. **Fig. 117**

117

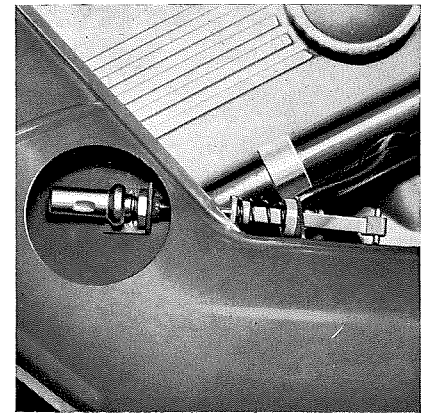

Check V-belt tension every 8000 miles (12000 km) during a BMW Program Test. The V-belts are correctly tensioned when V-belt 1 (between alternator and fan pulley) and V-belt 2 (between high-pressure vane type pump and fan pulley) can be depressed by 0.2–0.4" (5–10 mm) in the centre of the belt run. **Fig.118**

To retension V-belts:

V-belt 1

Loosen the upper and lower alternator securing bolts (13 mm spanner) (**Fig.119**) and move the alternator bodily along its retaining strap until the desired V-belt tension is obtained.

118

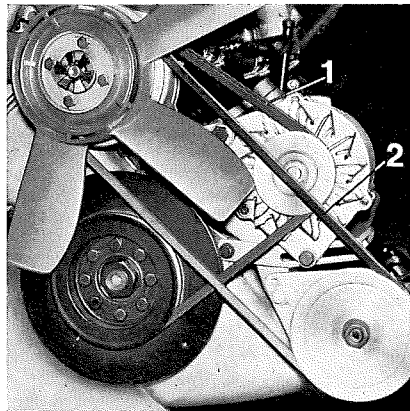

V-belt 2

Loosen the two bolts securing the high-pressure vane type pump (13 mm spanner) (**Fig. 119**) and retension the V-belt by moving the pump along the slotted fixing holes in its body.

To fit new V-belts:

V-belt 1

First remove V-belt 2

Loosen the upper and lower alternator securing bolts (13 mm spanner) (**Fig.119**) and push the alternator as close to the engine as possible. Pass the new V-belt over the vibration damper, fan and alternator pulleys, then retension as described above.

119

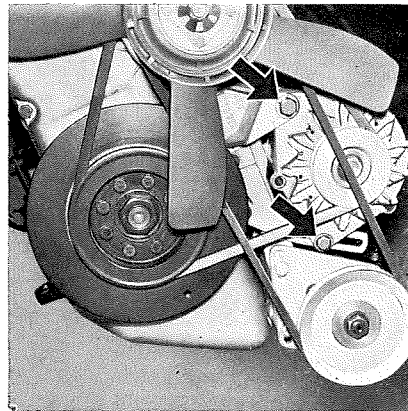

V-belt 2

Loosen the bolts securing the high-pressure vane type pump (13 mm spanner) (**Fig. 120**) and push the pump as far as possible towards the alternator. Fit the new V-belt over the fan and oil pump pulleys, and retension.

120

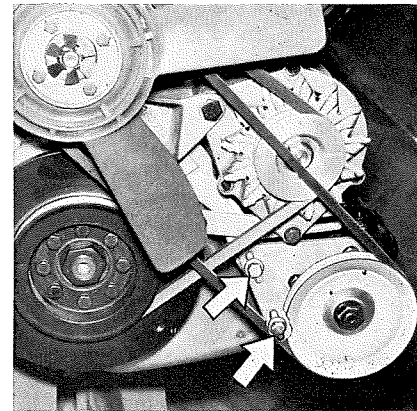

Adjusting handbrake:

If the handbrake lever can be pulled up by 5 notches without any braking effect becoming noticeable, the handbrake must be adjusted.

The handbrake should always be adjusted by a BMW service station. In an emergency, however, proceed as follows: Take the wheel hub caps off both rear wheels and unscrew the wheel nuts. Jack up the car. Remove both rear wheels and turn left brake disc so that the large sight hole is approx. 10° from the vertical position facing to the top at the rear. The large sight hole on the right brake disc must be approx. 10° from the vertical position facing to the top at the front.

121

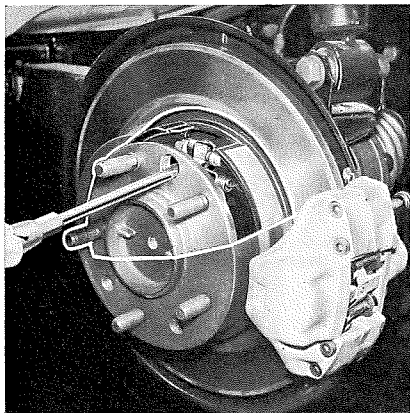

When adjusted to this position, the handbrake adjusting nut can be seen through the sight hole. Insert a screwdriver so that the blade engages with the serration on the adjusting nut.

Fig. 121

Turn the adjusting nut with the screwdriver to make the handbrake shoe rest in position, until the brake disc cannot be turned anymore. Then turn back the adjusting nut by 4–6 notches.

To apply handbrake turn screwdriver in downward direction. To release handbrake turn screwdriver in upward direction. Proceed in the same way for the wheel on the other side of the car.

Next, the handbrake cables must be adjusted. To do this, pull the rubber cover

122

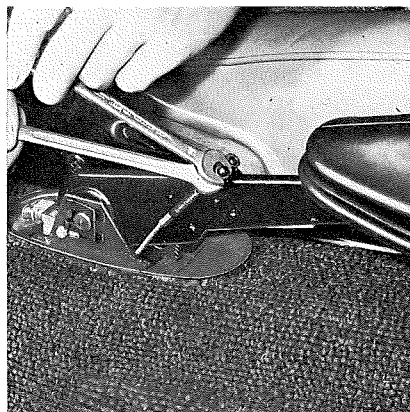

up along the handbrake lever. Unscrew the locknuts on each adjusting bolt (10 mm spanner), pull the handbrake lever up by 4 notches, screw up the adjusting nut (10 mm spanner) until all slack is removed — prevent the adjusting bolt from turning by gripping with pliers — and check that the rear wheel cannot rotate. Screw on and tighten locknuts.

Figs. 122 and 123

After adjusting the handbrake, always check that the rear wheels can rotate without binding when the handbrake is released. Check that both handbrake cables are acting with equal force by applying the handbrake lightly and turning the rear wheels by hand. Finally, put the wheels back on the car and tighten the wheel nuts.

123

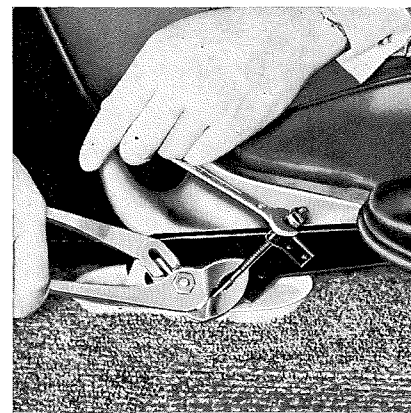

BMW 3.0 CS**Zenith Type 35/40 INAT two-stage carburettors Figs. 124 and 125**

1. Carburettor top cover
2. Connecting link between automatic choke and choke butterfly
3. Bedplate
4. Carburettor body
5. Throttle butterfly block
6. Vacuum chest
7. Connection for electric heating cable to automatic choke
8. Coolant connections for heating of automatic choke

124

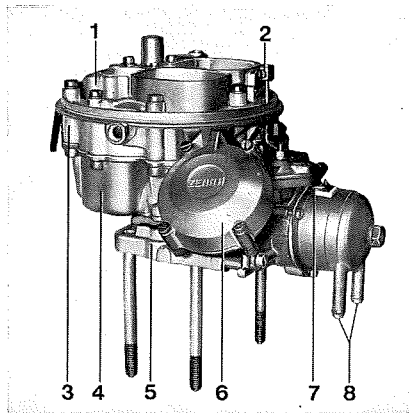

9. Choke butterfly
10. Accelerator pump lever
11. Automatic choke mechanism
12. Vacuum diaphragm housing
13. Idling speed adjusting screw
14. Connection for ignition timing mechanism
15. Idling mixture adjusting screw
16. Air supply changeover valve
17. Fuel feed

125

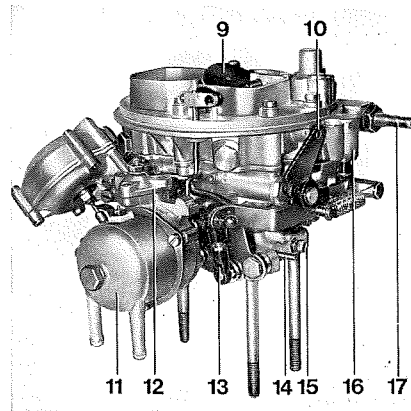

The Zenith Type 35/40 carburettors are of the two-stage type, with 35 mm 1st stage and 40 mm 2nd stage barrels. They are equipped with a combined automatic choke mechanism, the bi-metallic spring of which is both electrically heated and coolant heated. Carburettors and automatic choke mechanisms are maintenance-free in use.

Cleaning and adjustment work on the carburettors should be undertaken only by a BMW service station. The jets and basic settings adopted by the factory must not be altered.

See also Specifications.

Idling speed adjustment on the BMW 3.0 CSI

All adjusting work on the fuel injection system should be carried out by a BMW service station only, as these service stations have the necessary measuring equipment.

Please note the following makeshift method of adjusting the idling speed only in an emergency:

The idling speed may be adjusted **only** by means of the idling screw below the throttle butterfly sensor. **Fig. 126**

126

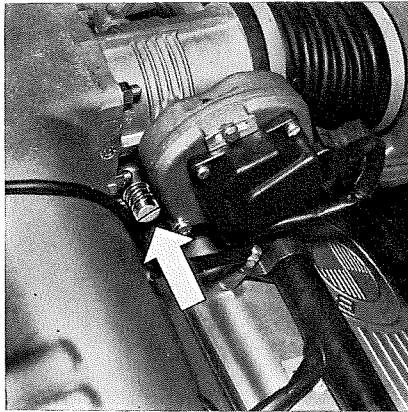

To reduce the amount of air in the mixture turn the idling screw clockwise: engine speed decreases.

To increase the amount of air in the mixture turn the idling screw counter-clockwise: engine speed increases.

Make sure that the correct procedure for adjusting the idling speed, as specified by the factory, is carried out by a BMW service station immediately afterwards.

Important:

Never pull off or put in the cable plug contact of the control unit when the ignition is switched on.

Never let the engine run with the battery disconnected.

Do not use a quick charger as a starting aid when starting the engine.

When charging the battery by means of a quick charger, disconnect battery from the car's electrical system.

Note battery poles when installing.





Wishing you
carefree driving

Specifications *

ENGINE

Type

6-cylinder, 4-stroke inline, water cooled, with single overhead camshaft, inclined overhead valves and triple-hemisphere combustion chambers with volume concentration effect around spark plugs.

Position

Over front axle, inclined at 30° from vertical, with 3-point location: front mounting close to centre of gravity, with 2 rubber mountings attached direct to the front axle beam on either side of the engine block. Rear of engine flanged to gearbox, with single rubber mounting on gearbox cross-member.

Cylinder block

Special grey cast iron

Cylinder head

Light alloy, with shrunk-in valve seats and guides.

Crankshaft

Forged steel, heat-treated, with 12 balance weights and 7 three-layer main bearings each with 2 oil supply drill-ways.

Connecting rods and pistons

Forged steel connecting rods with replaceable three-layer bearings. Pistons with raised flat crown and chromium-plated spheroidal graphite upper rings.

* not fully applicable for US models

Engine — BMW 3.0 CSI

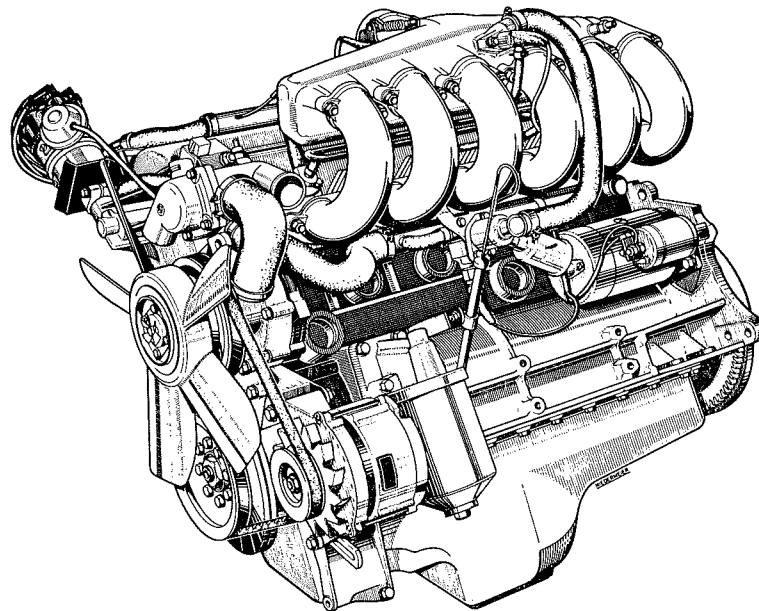

BMW 3.0 CS**Capacity**

fiscal	2966 cc	180.9 cu. in.
effective	2985 cc	184.4 cu. in.

Max. output

at engine speed	180 bhp (DIN) 6000 rpm	200 bhp (SAE) 6000 rpm
-----------------	---------------------------	---------------------------

Max. torque

at engine speed	26 mkp 3700 rpm	188 lb/ft 3700 rpm
-----------------	--------------------	-----------------------

Output per litre

60 bhp (DIN)

Max. permitted engine speed

6400 rpm

Max. continuous engine speed

6000 rpm

Compression ratio

9.0 : 1

Bore x stroke (ratio)80 x 89
(= 0.9) 3.150" x 3.404"**Mean piston speed at engine speed**16 m/sec.
6000 rpm 3150 ft/min.
6000 rpm**Torque/weight ratio (unladen)**18.8 mkp/1000 kg 137.5 lb/ft
per ton**Power/weight ratio**

in road trim, with full tank	7.65 kg/bhp	132.1 bhp/ton
with all seats occupied and luggage	9.7 kg/bhp	104.2 bhp/ton

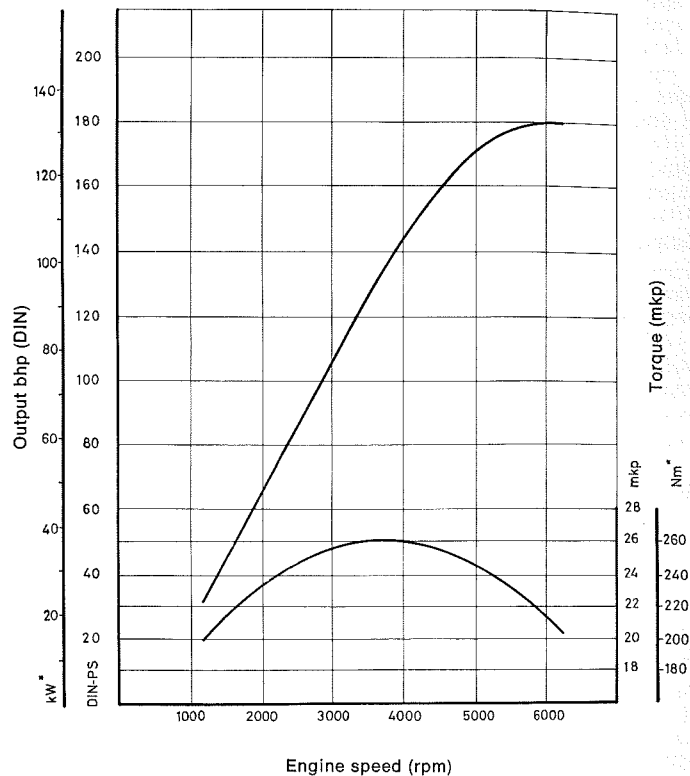
Engine output – BMW 3.0 CS

BMW 3.0 CSI

Capacity fiscal	2966 cc	180.9 cu. in.	
	effective 2985 cc	184.4 cu. in.	
Max. output at engine speed	200 bhp (DIN) 5500 rpm	222 bhp (SAE) 5500 rpm	
	Max. torque at engine speed	27.7 mkp 4300 rpm	199.2 lb/ft 4300 rpm
Output per litre	67 bhp (DIN)		
Max. permitted engine speed	6400 rpm		
Max. continuous engine speed	6000 rpm		
Compression ratio	9.5:1		
Bore x stroke (ratio)	80 x 89	3.150" x 3.404"	
	(= 0.9)		
Mean piston speed at engine speed	14.67 m/sec. 5500 rpm	2888 ft/min. 5500 rpm	
	Torque/weight ratio (unladen)	20.1 mkp/1000 kg	145.6 lb/ft per ton
Power/weight ratio in road trim, with full tank	6.9 kg/bhp	147.5 bhp/ton	
	with all seats occupied and luggage	8.75 kg/bhp	121.7 bhp/ton

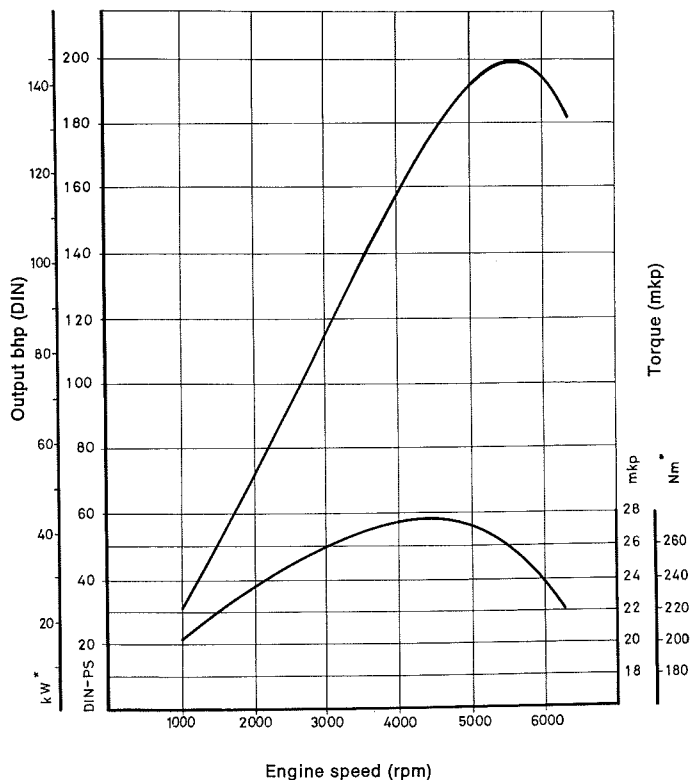
Engine output – BMW 3.0 CSI

Valves

In cylinder head; inverted V arrangement. Exhaust valve armoured, with stem hard chromium plated. Valve clearance adjustment by means of eccentrics in rockers.

Valve gear

Light alloy rockers with chill-cast pads, overhead camshaft. Camshaft drive by duplex roller chain with automatic oil-damped tensioner and recoil protection.

Engine breathing

Crankcase and valve chest connected by cast-in passage, and ducted to intake air filter and manifold (BMW 3.0 CS), or to throttle butterfly manifold (BMW 3.0 CSI).

Valve operating clearances

Inlet and exhaust: 0.01–0.012" (0.25–0.30 mm), measured with engine stopped and cold or max. coolant temperature of 95° F (35° C).

Valve timing for test purposes

Inlet opens	14° BTDC
Inlet closes	54° ABDC
Exhaust opens	54° BBDC
Exhaust closes	14° ATDC

Measured with 0.02" (0.5 mm) clearance, between rocker and cam base circle.
Opening period 248° at crankshaft.

Road speed — engine speed BMW 3.0 CS

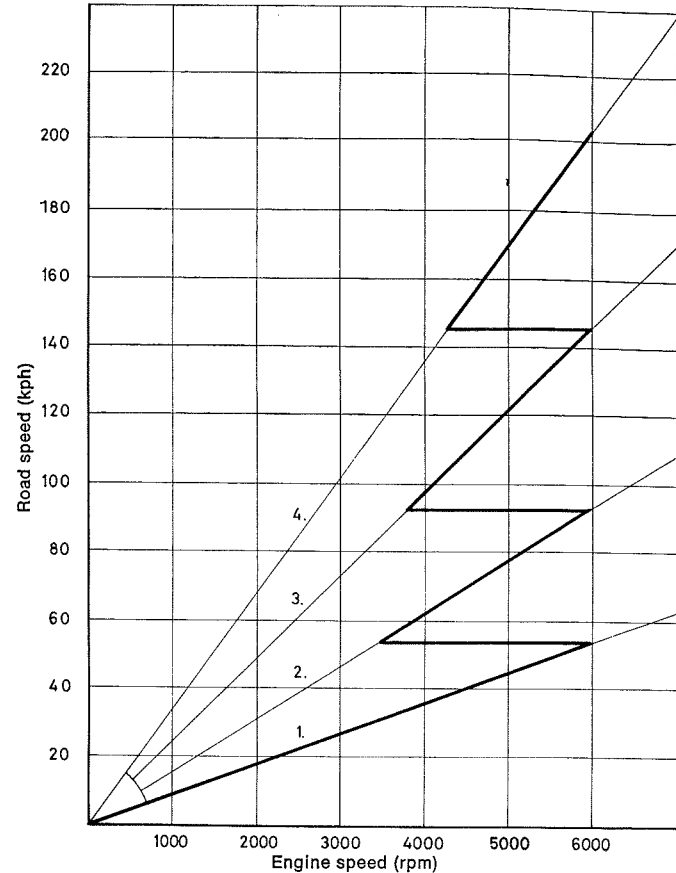

Lubrication

Pressure oil circulation with full-flow oil filter and pressure regulating valve in filtered oil circuit; rotor type oil pump (Eaton system) chain-driven from crankshaft, light alloy sump.

Oil filter

Full-flow, with paper element and pressure relief valve opening at 36 ± 2.8 psi (2.5 ± 0.2 atm).

Oil consumption

approx. 5500–2800 mpg (0.05–0.1 litres per 100 km).

Air filter

Two elements – BMW 3.0 CS
one element – BMW 3.0 CSi
in intake air silencer.

Radiator type

Cross-flow gilled tube, with equalizing reservoir; pressure relief and vacuum valve in reservoir cap.

Opening pressure of cap valves:

Pressure relief: $14.2 \begin{matrix} +2.1 \\ -1.4 \end{matrix}$ psi
($1 \begin{matrix} +0.15 \\ -0.10 \end{matrix}$ kg/cm²)

Vacuum: max. 1.4 psi (0.1 kg/cm²)

Fan

Automatic on/off switch controlled by heat-sensitive expanding element (F&S system).

Fuel consumption

(DIN 70030 standard test method)

BMW 3.0 CS: 26.8 mpg (Imp.)/22.2 mpg (US)/10.6 litres per 100 km
BMW 3.0 CSi: 28.5 mpg (Imp.)/23.8 mpg (US)/9.9 litres per 100 km

BMW 3.0 CS

Carburettor type	2 Zenith 35/40 INAT two-stage	
Carburettor settings	1 st stage	2 nd stage
Air venturi (cast-in)	24	30
Main jet	X 117.5	X 145 (X 155 on Automatic model)
Mixture tube	6 S	4 N
Air corrector jet	80	120
Idling jet	47.5	
Intermediate jet		60

Coolant thermostat

Thermostatic control of coolant circulation in input flow to engine, with automatic equalization of engine load and outside temperature variations (BMW system).

Opens: 183° F (84° C) for BMW 3.0 CS/CSi or 175° F (80° C) for BMW 3.0 CS-A (Mixing temperature, corresponding to approx. 194°–207° F (90°–97° C) at outlet from engine.)

Fuel supply BMW 3.0 CS

Mechanical fuel pump, pressure 2.85–3.5 psi (0.21–0.25 kg/cm²) at 4000 rpm.

Fuel filters

Fine mesh filters in both fuel pump and pick-up tube in tank.

Fuel supply BMW 3.0 CSi

Electrical roller-cell pump, delivery rate approx. 120 litres/hr.

Fuel filters

Fine mesh filter in the intake unit of the fuel tank, fine mesh filter in the induction pipe of the electrical fuel delivery pump.

Full-flow filter in the engine.

Fuel supply

BMW 3.0 CS: 2 two-stage Zenith 35/40 INAT carburettors

BMW 3.0 CSi: BOSCH electronic fuel injection.

CLUTCH

Single dry plate with diaphragm spring and hydraulic withdrawal mechanism; torsional vibration damper fitted. Automatic adjustment of operating clearance. Automatic transmission: fluid coupling with torque converter.

GEARBOX

- a) manual: four-speed Getrag 262/8 with Borg Warner synchromesh on all forward gears, one reverse gear.
- b) automatic: Borg Warner transmission with oil cooler.

Gear ratios

	Manual four-speed	Automatic transmission
1st	3.855:1	2.39:1
2nd	2.202:1	1.45:1
3rd	1.401:1	1.0 :1
4th	1.0 :1	—
Rev.	4.3 :1	2.09:1

Torque converter ratio

1–2.0:1

PROPELLER SHAFT

Divided, with front rubber coupling and centering bearing, centre and rear universal joints with needle roller bearings; flexible centre bearing mounting.

Road speed — engine speed BMW 3.0 CSI

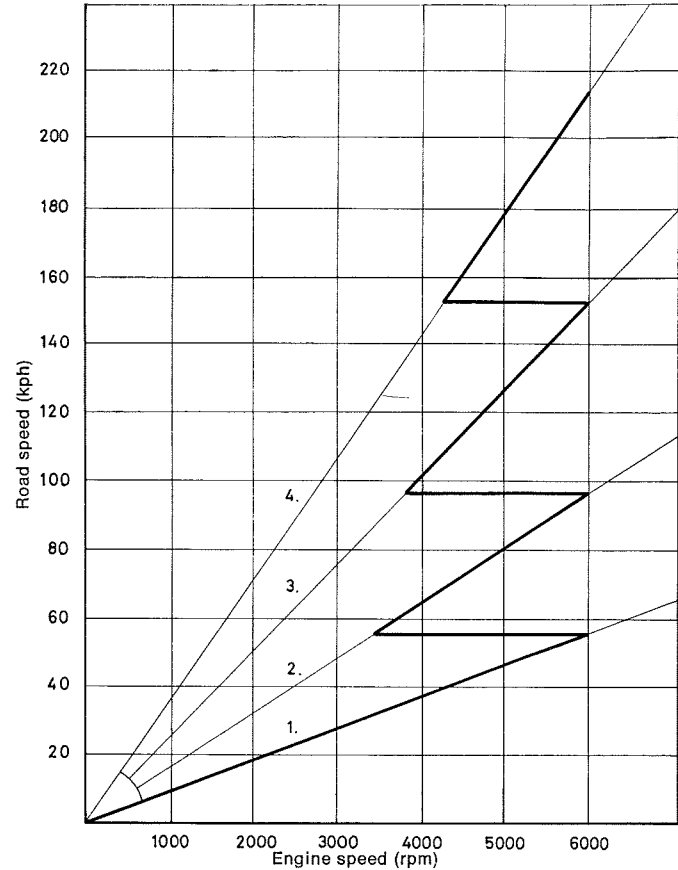

FINAL DRIVE

Hypoid bevel pinions with taper roller bearings.

Ratios**BMW 3.0 CS**

Crown wheel/ pinion	No. of teeth	Contact pattern
3.45:1	38:11	Klingelberg or Gleason

BMW 3.0 CSI

Crown wheel/ pinion	No. of teeth	Contact pattern
3.25:1	39:12	Klingelberg

Optional: ZF Lok-0-Matic disc type limited-slip differential.

Rear axle

Left and right halfshafts with 2 no-maintenance homokinetic universal joints.

CHASSIS**Front suspension**

Independent, with lower wishbones, trailing links and spring/shock absorber struts; struts inclined rearwards at top, and incorporating double-acting hydraulic shock absorbers. Wishbones and trailing links pivoting in large-diameter rubber bushes; strut centre-line and wheel axis offset to provide the desired caster angle displacement; coil springs high mounted and offset in relation to strut axis; rubber auxiliary springs; total wheel travel 7.1" (180 mm). Torsion-bar stabilizer mounted in no-maintenance rubber bushes.

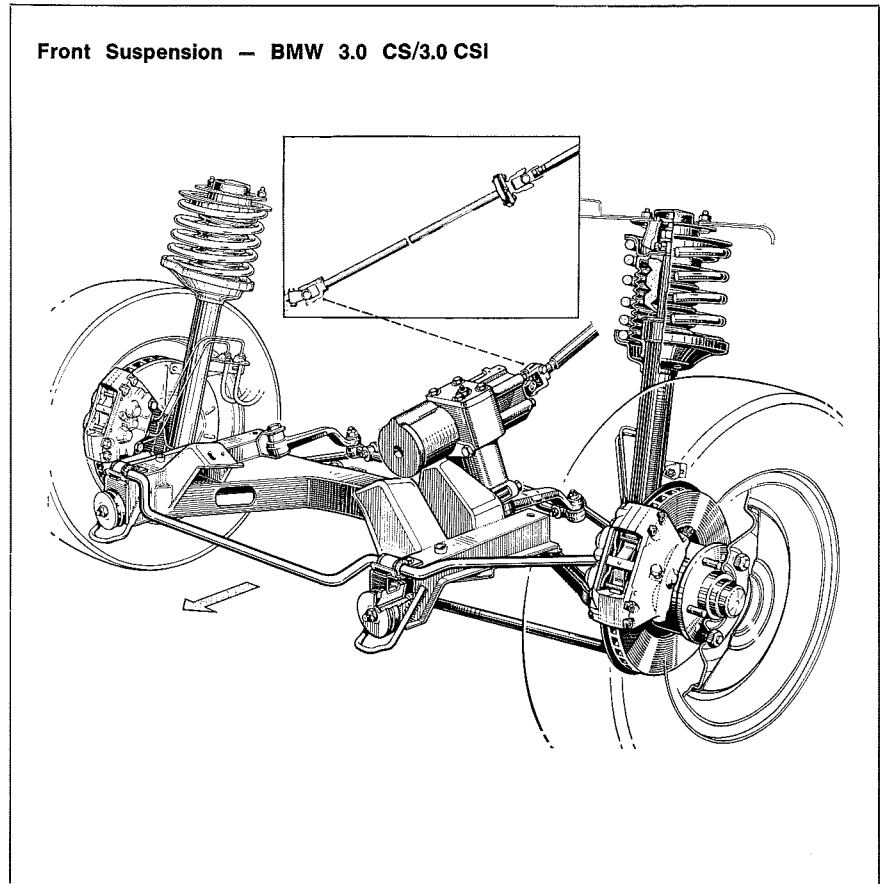
Front Suspension — BMW 3.0 CS/3.0 CSI

Toe-in in normal load position*
 $0.04 \pm 0.04''$ (1 ± 1 mm)

Camber angle in normal load position*
 $0^\circ \pm 30'$

Castor angle $9^\circ 30' \pm 30'$

Kingpin inclination $6^\circ 20'$

Toe-out on turns (20° lock on inner wheel) $1^\circ 30'$

Max. wheel lock

Inner wheel $45^\circ 45'$

Outer wheel 35°

Rear suspension

Independent, with semi-trailing arms pivoting on no-maintenance rubber bushes. Delta-shaped box-section rear axle beam for semi-trailing arms and final drive, bolted to body shell at 3 points by means of rubber mountings with built-in longitudinal compliance. Coil springs and rubber auxiliary springs, total wheel travel 7.9" (200 mm), double-acting telescopic hydraulic shock absorbers. Torsion bar stabilizer mounted in no-maintenance rubber bushes.

Toe-in in normal load position*
 $0.04 \pm 0.04''$ (1 ± 1 mm)

Camber angle in normal load position*
 $2^\circ \pm 30'$ negative

Steering

ZF ball and nut hydraulic power steering.

Ratio 15.7:1

Overall ratio 18.1:1

* Normal load position: vehicle with full tank and 2 x 143 lb (2 x 65 kg) on front seats, 143 lb (1 x 65 kg) on rear seat, 66 lb (30 kg) in luggage compartment.

Rear Suspension — BMW 3.0 CS/3.0 CSI

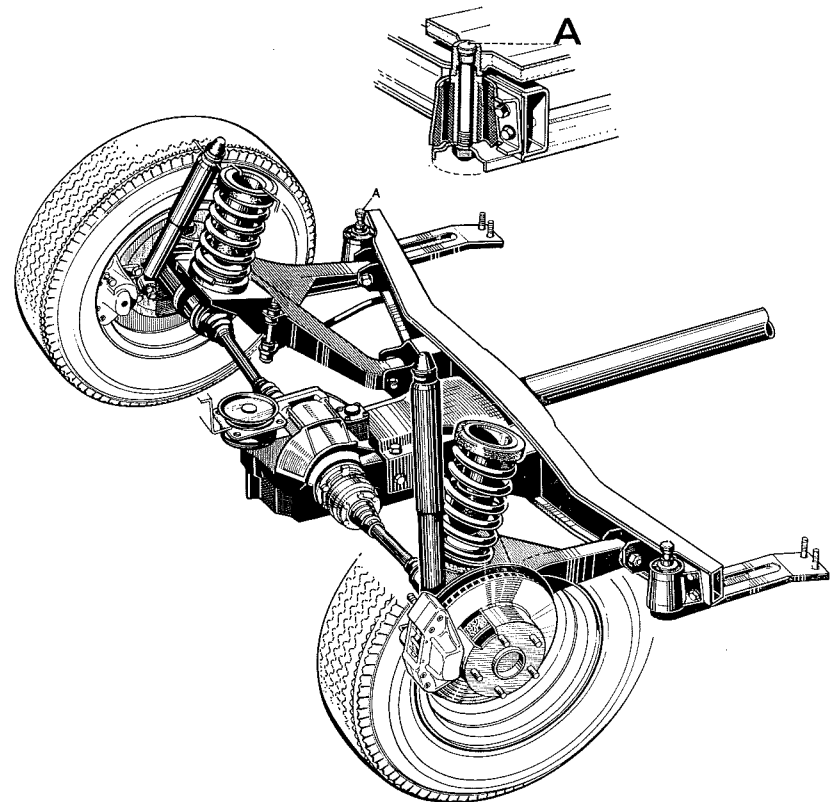

Safety steering column

with 2 universal joints and 1 plate type joint.

Track rod 3-piece**Light-alloy wheels**

6 J x 14 well-base rims

Tyres

195/70 VR 14 radial-ply, tubed, with screw-in metal valve (40 G DIN 7771). Winter tyres: 175 SR 14 mud & snow or mud, snow & ice, or DR 70 SR 14 mud & snow or mud, snow & ice. Snow chains may be fitted only when using winter tyres 175 SR 14 mud & snow or mud, snow & ice.

BRAKES**Foot brake****(Twin dual-circuit system)**

Hydraulic, operating on all 4 wheels, and including brake servo Mastervac (BMW 3.0 CS) or dual Mastervac for BMW 3.0 CS-A, 3.0 CSi and US models (9"; RHD, Hydrovac T 50/29/33). Tandem master cylinder, 9.4" (23.81 mm) or 9" (22 mm) dia.; in conjunction with Mastervac transparent fluid reservoir in engine compartment with electrical low level warning contact and telltale lamp in revolution counter.

Front:

4-piston fixed caliper disc brakes with automatic pad wear compensation.

Disc diameter 10.7" (272 mm)
Piston diameter 1.57" (40 mm)

**Diagram of hydraulic twin dual-circuit
brake system — BMW 3.0 CS/CSi**

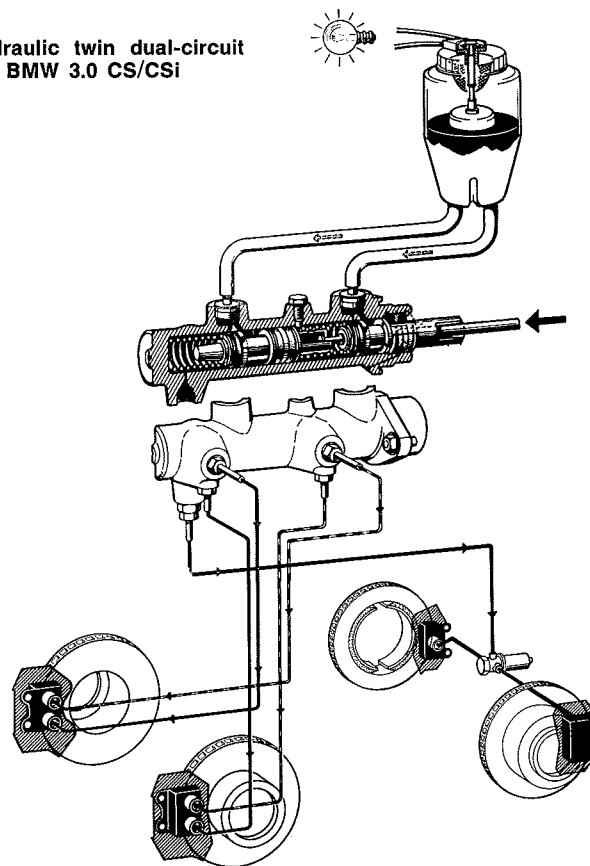

Rear:

2-piston fixed caliper disc brakes with automatic pad wear compensation.

Disc diameter 10.7" (272 mm)

Piston diameter 1.57" (40 mm)

All brake discs are internally ventilated.

Handbrake

Duo-Servo drum brake operating mechanically on rear wheels. Adjustment: adjusting nuts on brake shoes and hand-brake lever, under the rubber sleeve. Cable to each rear wheel adjustable separately.

Drum diameter 6.3" (160 mm)

Lining width 0.98" (25 mm)

Brake pressure limiter for rear wheels
Cut-in pressure 285 ± 28 psi (20 ± 2 atm).

Stopping distances

The stopping distance is made up of the distance covered during the approx. 1 second reaction time (at 100 kph = 62 mph, about 28 metres = 92 feet), the time needed for the brakes to act and the actual braking distance.

The best possible brakes can only attain an efficiency corresponding to the available friction between tyres and road surface. As the graph shows, the maximum possible retardation of a vehicle travelling on an icy surface is only in the region of 4.9 ft. per sec² (1.5 m/sec²).

This implies that your car's speed is reduced by only 4.9 feet per second; in other words, every second the speed drops by 3.375 mph (5.4 kph). If you had, for example, been travelling at 34 mph (54 kph), it would therefore take

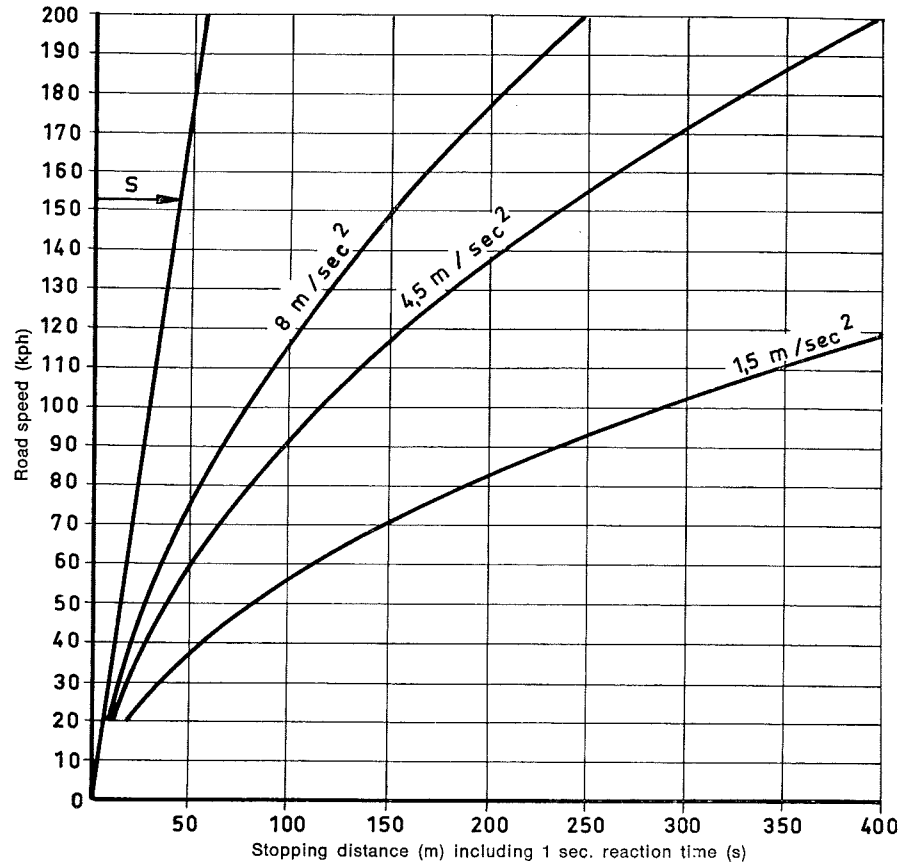
Stopping distance related to road speed and retardation

you about 10 seconds to stop. As the graph shows, you would cover almost 330 feet (100 metres) in that time.

The lowest curve (1.5 m/sec^2) shows you your braking distance related to road speed under the conditions just described.

In contrast, the uppermost curve (8 m/sec^2) refers to the shortest braking distances generally obtainable in ideal conditions.

The middle curve (4.5 m/sec^2) applies to a damp road not entirely devoid of grip for the tyres, and thus represents an average set of values for normal-strength braking during everyday driving on dry roads.

All the values on the graph can vary for better or worse depending on the state of your brakes, tyre condition and the road surface itself.

The braking distances quoted include a proportion «s» covered during one second's reaction time on the part of the driver.

Most effective braking takes place not with locked wheels, but when the wheels are still just turning.

Locking the wheels can be dangerous, as locked front wheels can no longer be steered, and locked rear wheels cause the car to slide sideways or spin.

Heating — BMW 3.0 CS/CSi

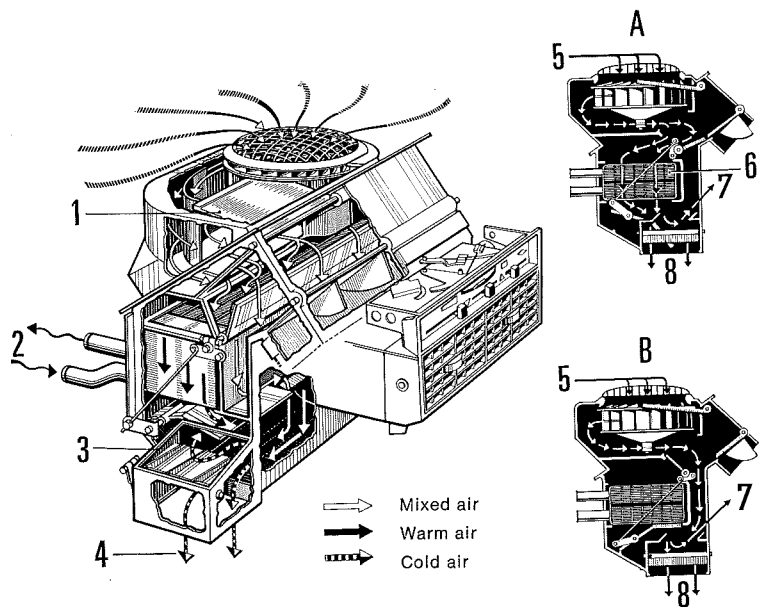

1. Main on/off valve
2. Coolant supply and return
3. Airflow to demister outlets
4. Airflow to footwells

- A Flow pattern with full heat output
5. Cold air supply
 6. Heat exchanger
 7. To demister outlets
 8. To footwells

- B Flow pattern with cold air supply only
5. Cold air supply
 7. To demister outlets
 8. To footwells

BODYWORK

Load-bearing all-steel bodyshell welded to floor section to form a particularly torsion-resistant complete unit.

Doors and engine compartment lid hinged at front.

Luggage compartment: 59.1" (1500 mm) wide, 41.3" (1050 mm) deep, 12.2" (310 mm) high, capacity 15.9 cu. ft. (450 litres).

Fuel tank: capacity 15.4 gal. (Imp.)/18.5 gal. (US)/70 litres.

Heating and ventilation

Fresh-air heater with hot water heat exchanger permanently in circuit and three-speed radial blower (140 Watt); airflow 106, 159 or 212 cu. ft. per min. (3, 4.5 or 6 cu. m/min.). Instant temperature selection within fine limits by means of 4-lever control system. Total of 4 footwell and front screen demister outlets, with airflow to front side windows if required.

Independently of hot air supply, cold air can be supplied to an outlet grill in the centre of the fascia, adjustable in any desired direction. This ensures stratified interior air temperatures for fatigue-free driving.

Stale air extraction through slots above the rear window leading to outlets on the rear roof pillars (not on cars fitted with a sliding roof).

Ventilation – BMW 3.0 CS/CSI

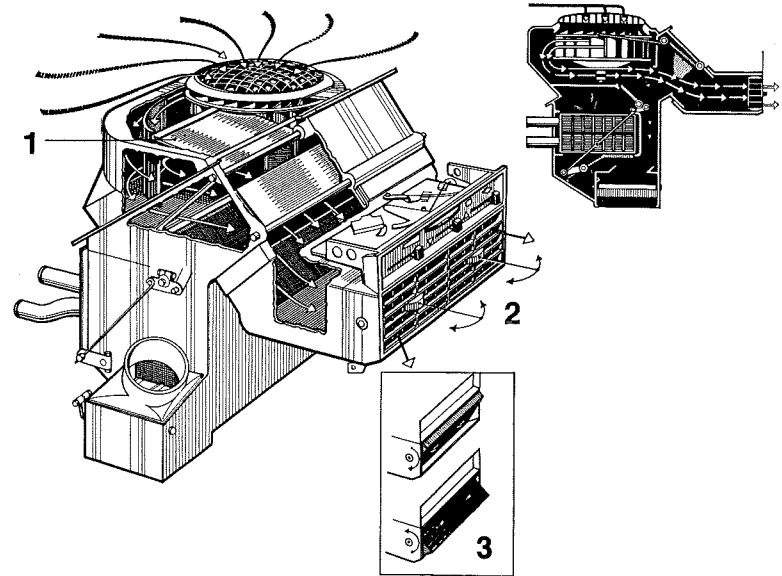

1. Main on/off valve
2. Lateral directing vanes
3. Vertical pivoting grille

ELECTRICAL SYSTEM**BMW 3.0 CS/3.0 CSI**

Battery 12 Volt, 55 Amp/hr

High-performance coil Bosch KW 12 V

Primary resistance 9 Ohm

BMW 3.0 CS

Distributor Bosch JFUDR 6
(with double vacuum socket)

Ignition advance

centrifugal and vacuum

Centrifugal advance

Begins: approx. 640 rpm of crankshaft
Ends: approx. 3000 rpm of crankshaft
Max. adjustment range: 26° at crankshaft

Vacuum advance

Advance control (advance socket)
Begins: approx. 5.31" (135 mm) Hg
Ends: approx. 10.83" (275 mm) Hg
Max. adjustment range: 14° at crankshaft

Retarded control (retard socket)
Begins: approx. 7.68" (195 mm) Hg
Ends: approx. 12.8" (325 mm) Hg
Max. adjustment range: 12° at crankshaft

Alternator

Bosch K 1 — 14 v 45 A 22 (630 W)

BMW 3.0 CSI

Distributor Bosch PFUDX 6
(with release contacts)

Ignition advance

centrifugal and vacuum

Centrifugal advance

Begins: approx. 1000 rpm of crankshaft
Ends: approx. 3500 rpm of crankshaft
Max. adjustment range: 20° at crankshaft

Vacuum advance

Begins: approx. 7.28" (185 mm) Hg
Ends: approx. 11.02" (280 mm) Hg
Max. adjustment range: 10° at crankshaft

Alternator

Bosch K 1 — 14 v 55 A 20 (770 W)

BMW 3.0 CS/3.0 CSI

Ignition timing 22° BTDC (marking)
at 1700 rpm BMW 3.0 CS, and
2500 rpm BMW 3.0 CSI

Adjust dynamically without vacuum advance with engine at normal operating temperature (speed: 1700 rpm or 2500 rpm resp.); illuminate timing mark on flywheel with a stroboscopic light pistol.

Firing order: 1-5-3-6-2-4

Contact breaker dwell angle 35°-41°
(BMW 3.0 CS) or 39°-45° (BMW 3.0 CSI)

Contact breaker points gap

0.014-0.016" (0.35-0.40 mm)

Voltage regulator

Bosch AD 1/14 V

Starter

Bosch GF 12 V 1.2 PS (1.2 hp)

Spark plugs

Beru 175/14/3 A
Bosch W 175 T 30
Champion N 9 Y
Special equipment:
Beru G 175/14/3
Bosch WG 175 T 30
(air surface gap)
Electrode gap: 0.024+0.004"
(0.6+0.1 mm)

Headlights

Main beam: 2 inner quartz-iodine (high),
plus 2 outer quartz-iodine (low).

Dipped beam: 2 outer asymmetric quartz-iodine, including side/parking lights.
Lens diameter 5.4" (136 mm)

Bulbs: 12 V

see pages 49-51

Fusebox

in passenger compartment under the instrument panel on the left hand side; 10 poles.

For key to fuses, see page 48.

Cigar lighter and plug socket on instrument panel

to be used for plugging in an inspection lamp or razor etc. with standard plug; max. 200 Watt, 12 Volt rating.

Screenwipers

Twin blades, with three-speed preselector switch on instrument panel and push switch on flasher lever for interval or continuous operation.

Automatic screenwasher

Electric gear type pump with delay relay for wipers, operated by flasher lever.

Horns

Two electric twin-tone horns under front of engine compartment lid; well positioned for maximum audibility and protected against dirt and dust.

Heated rear window

with 9 burnt-in heat conducting wires. Power supply 95 ± 5 Watt.

DIMENSIONS AND WEIGHTS

Length	183.5" (4660 mm)
Width	65.7" (1670 mm)
Height (unladen)	53.9" (1370 mm)
Wheelbase	103.3" (2625 mm)
Ground clearance (laden)	5.5" (140 mm)
Front overhang	37.6" (955 mm)
Rear overhang	42.5" (1080 mm)
Front track	56.9" (1446 mm)
Rear track	55.2" (1402 mm)
Min. track circle	31.6' (9.6 m)
Min. turning circle	34.5' (10.5 m)
Unladen weight (in road trim with full tank)	3043 lb (1380 kg)
Max. permitted gross weight	3859 lb (1750 kg)
Permitted front axle load	1984 lb (900 kg)
Permitted rear axle load	1984 lb (900 kg)
Permitted trailer load	
unbraked	1433 lb (650 kg)
braked	2866 lb (1300 kg)
Permitted roof load	165 lb (75 kg)
(When fully laden, the permitted axle loads must not be exceeded.)	

Interior dimensions (in mm)

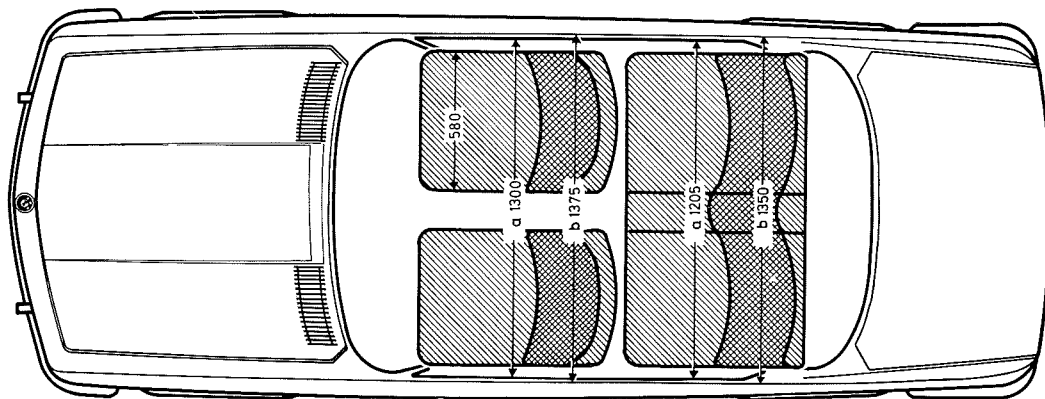
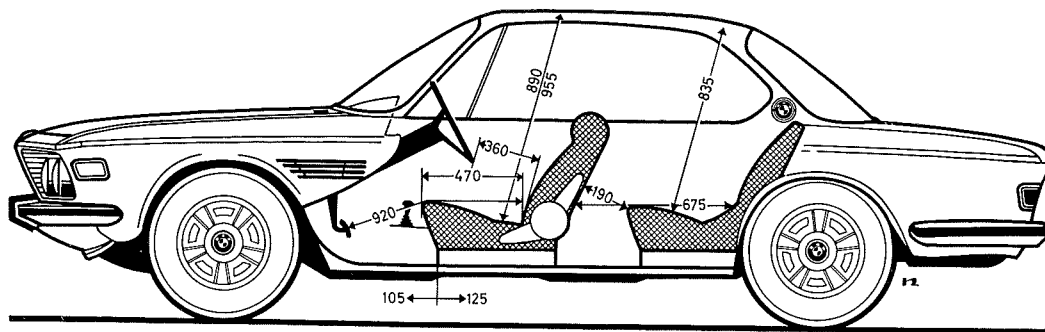

a = width at hip height
b = width at shoulder height

PERFORMANCE**BMW 3.0 CS****Max. gradients**

1st gear	58 %	1 in 1.77
2nd gear	37 %	1 in 2.6
3rd gear	21 %	1 in 4.8
4th gear	13 %	1 in 7.9

Acceleration

Gears	mph	kph	sec.
-1st	0- 31	0- 50	2.7
-2nd	0- 50	0- 80	5.8
-3rd	0- 62	0-100	8.2
-3rd	0- 75	0-120	11.9
-3rd	0- 87	0-140	15.7
-4th	0-100	0-160	22.3

Standing-start kilometer (3280 feet)
in 29.5 sec.

Average speed 75.6 mph (122 kph)
Terminal speed 111.3 mph (178 kph)

Top speeds

BMW 3.0 CS 132 mph (213 kph)
BMW 3.0 CSA 128 mph (207 kph)

Max. continuous engine speed 6000 rpm

Max. permitted engine speed 6400 rpm

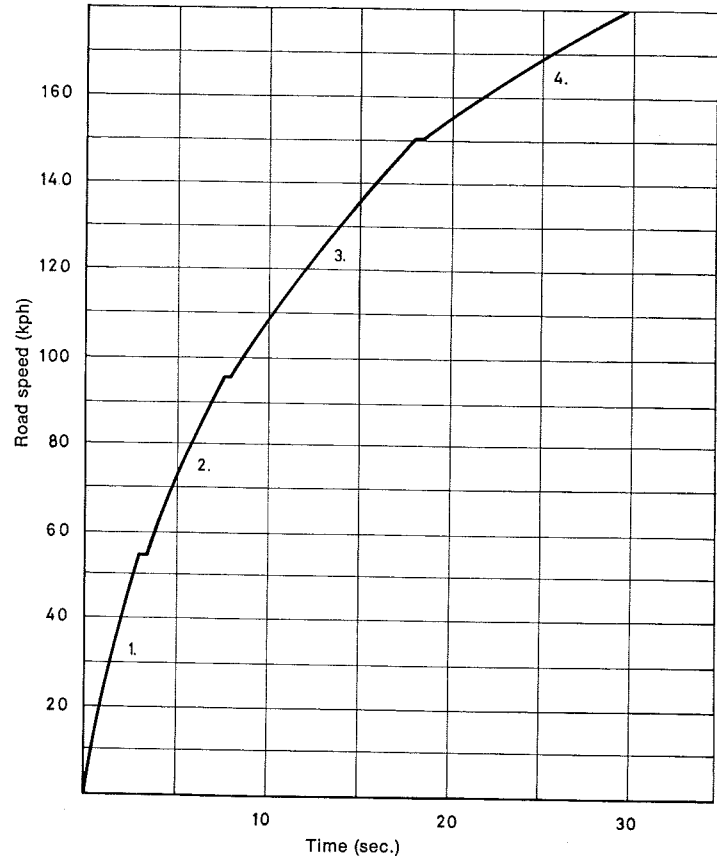
Acceleration through gears – BMW 3.0CS

BMW 3.0 CSI**Max. gradients**

1st gear	58 %	1 in 1.77
2nd gear	37 %	1 in 2.6
3rd gear	20 %	1 in 5.1
4th gear	12 %	1 in 8.3

Acceleration

Gears	mph	kph	sec.
1st	0- 31	0- 50	2.5
2nd	0- 50	0- 80	5.5
3rd	0- 62	0-100	7.7
3rd	0- 75	0-120	11.2
3rd	0- 87	0-140	14.6
4th	0-100	0-160	19.4

Standing-start kilometer (3280 feet)
in 28.6 sec.

Average speed 78.1 mph (125.9 kph)

Terminal speed 114.1 mph (184 kph)

Top speed

BMW 3.0 CSI 136 mph (220 kph)

Max. continuous engine speed 6000 rpm

Max. permitted engine speed 6400 rpm

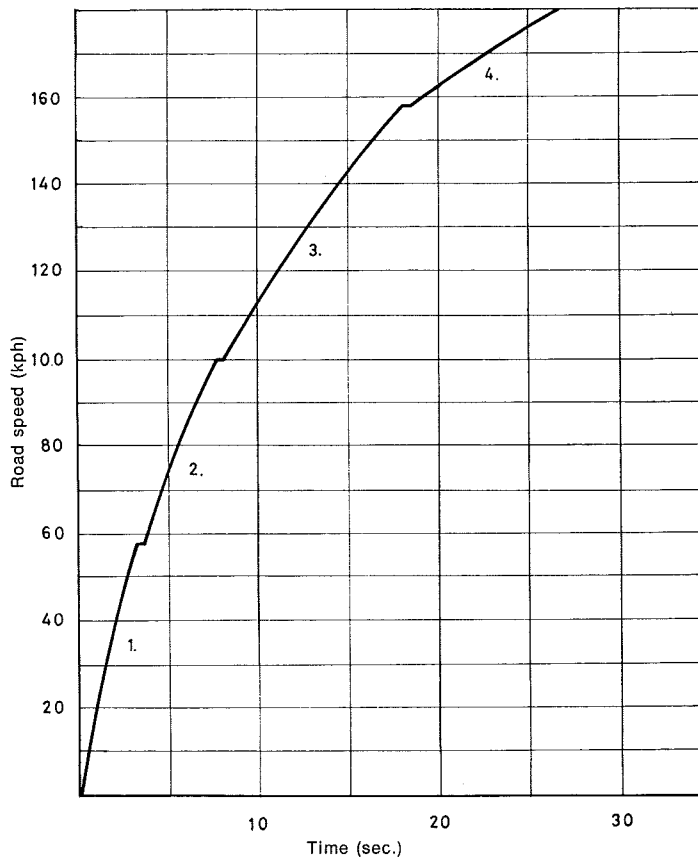
Acceleration through gears – BMW 3.0 CSI

**TIGHTENING
TORQUE VALUES
FOR NUTS
AND BOLTS**

	lb/ft	mkp		lb/ft	mkp
Engine					
Cylinder head studs	51±1.4	7±0.2	Spring/shock absorber strut, lower end	83+9.4	11.5+1.3
Vibration damper on crankshaft shoulder nut	325	45	Halfshaft to drive flange	43+5.1	6+0.7
Coolant pump pulley	29	4	Halfshaft to final drive shaft	43+5.1	6+0.7
Support bracket on engine	34	4.7	Propeller shaft to gearbox flange	46+5.1	6.4+0.7
Rubber mounting nuts	18	2.5	Rubber mountings on rear axle beam	17+4.3	2.4+0.6
Gearbox			Driving flange to rear axle shaft pinion	65+7.2	9+1
Flange mounting to engine	18 (M8)	2.5 (M8)			
Joint disc	34 (M10)	4.7 (M10)	Steering		
	75.9+9.4	10.5+1.3	Steering wheel retaining nut	40+3.6	5.5+0.5
Front axle			Joint disc and universal joint attachment	13.7+3.6	1.9+0.5
Spring strut, centre top	52+5.8	7.2+0.8	Joint flange attachment	13.7+3.6	1.9+0.5
Spring strut thrust bearing	16+2.2	2.2+0.3	Steering drop arm at steering box	57+14.5	12+2
Track rod arm at kingpin	16+2.2	2.2+0.3	Track rod castellated nuts	25+3.6	3.5+0.5
Guide joint at track rod arm	43+7.2	6+1	Steering box to front axle beam	29+5.1	4+0.7
Front axle beam to engine mounting	53+5.8	7.3+0.8	Steering drop arm bearing	58+14.4	8+2
Wishbone to front axle beam*	109+14.4	15+2	Track rod clamp bolts	5.7+2.2	1.2+0.3
Trailing link to wishbone and front axle beam*	43.4+14.4	6+2			
Rear axle			Brakes		
Final drive casing to body floor	59+6.5	8.1+0.9	Brake disc to wheel	43+5.1	6+0.7
Final drive to rear axle beam	47+7.2	6.5+1	Caliper to kingpin	58+10.8	8+1.5
Rear axle beam to body floor	78+8.7	10.8+1.2	Wheel nuts	58+7.2	8+1
Thrust link to body floor	17+4.3	2.4+0.6			
Semi-trailing arm to axle beam*	48+5.8	6.7+0.8			

* With car under normal load: full tank, 2 x 143 lb (2 x 65 kg) on the front seats, 143 lb (1 x 65 kg) on the rear seat, and 66 lb (30 kg) in the luggage compartment.

Key to lubrication chart

1. Fuel filler	Super (premium) grade fuel (see page 56)
2. Radiator filler cap on equalizing reservoir (Drain taps on radiator and engine block, see page 66)	For details, see page 41 ▲ Check antifreeze concentration before and during the cold season
3. Engine oil filler	◆ Branded HD 4-stroke engine oil For grades, see page 61 ◇ indicates oil change
4. Fuel pump fine mesh filter	≡ indicates filter cleaning
5. BMW 3.0 CSI: Clean or renew pre-filter in the intake unit of the fuel tank, fine-mesh filter in the inflow pipe of the fuel delivery pump, and full-flow filter every 40 000 miles (60 000 km) (see pages 68, 69)	≡ indicates filter cleaning ≡ indicates filter cleaning ⊕ indicates filter renewal
6. Battery	I Distilled water
7. Engine oil filter	⊕ indicates filter renewal
8. Intake air filter	≡ indicates filter cleaning ⊕ indicates filter renewal
9. Engine oil dipstick	Check oil level regularly
10. Hydraulic power steering	+ Check oil level regularly (see page 63) For oil grades, see page 105
11. Brake and clutch fluid reservoir	▼ Renew fluid in brake system once a year (grades, see page 64)
12. Wheel bearings (examine every 40 000 miles/60 000 km)	Shell Darina II grease, drip point above 260° C (500° F)
13. Distributor (for lubricating points, see page 64)	◆ Branded HD engine oil; Bosch Ft 1 v 4 or Ft 1 v 26 grease
14. Automatic transmission	Check oil level regularly (for oil grades, see page 105)
15. Manual gearbox (change oil every 22 000 miles/36 000 km)	● Branded gear oil, SAE 80 (in an emergency, HD engine oil, see page 61)
16. Final drive	◆ Branded running-in grade hypoid gear oil, SAE 90 (factory-approved grades can be recommended by your BMW service station)

Lifting points for single column car hoists with 4 pick-up pads:

Outer extremity of body, under the seam directly adjacent to the reinforced points used for the car's own jack.

Warning: If the car is jacked up directly beneath the front axle support or the final drive, use suitable hoisting equipment or place a suitable piece of material between the jack pad and the housing to prevent damage to the final drive.

Lubrication chart

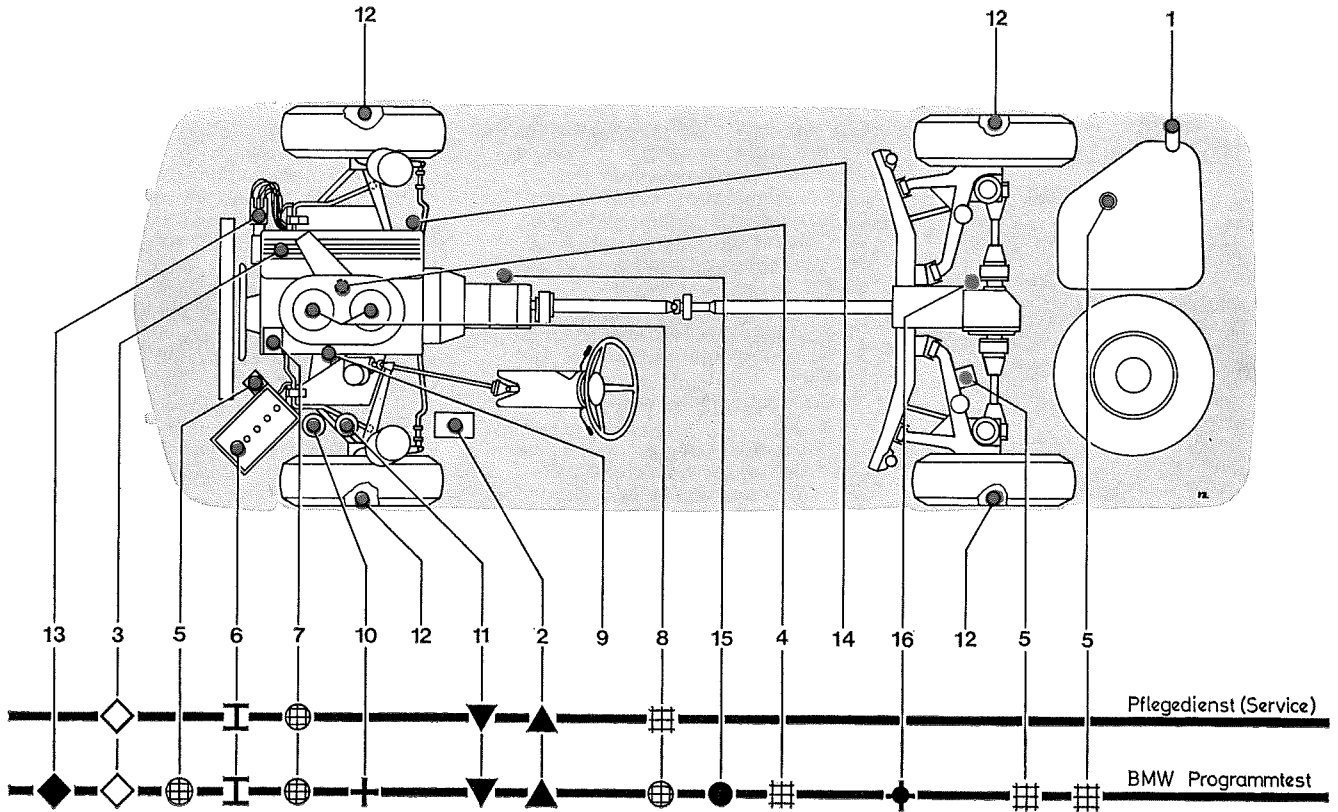

Key to electrical wiring diagram BMW 3.0 CS/A

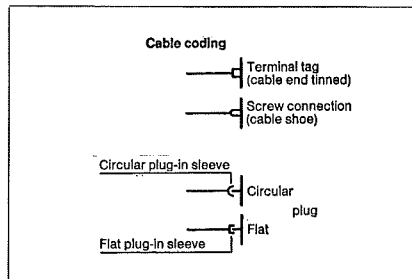

- 1 Turn indicator, front right
- 2 Earth (ground)
- 3 Low beam headlight with parking light, right
- 4 High beam headlight, right
- 5 Horn, right
- 6 Horn, left
- 7 High beam headlight, left
- 8 Low beam headlight with parking light, left
- 9 Turn indicator, front left
- 10 Earth (ground)
- 11 Connection for engine compartment light
- 12 Engine compartment light
- 13 Switch for engine compartment light
- 14 Solder tag
- 15 Connection for fog light relay
- 16 Fog light relay

- 17 Battery, 12 Volt
- 18 Horn relay
- 19 Voltage regulator
- 20 Alternator
- 21 Distributor
- 22 Primary resistance
- 23 Coil
- 24 Diagnosis plug-in connection with cable and contact
- 25 Automatic choke, front
- 26 Automatic choke, rear
- 27 Starter
- 28 Coolant thermometer contact
- 29 Connection to automatic choke
- 30 Oil pressure contact
- 31 Diagnosis plug-in connection
- 32 Brake fluid level telltale contact
- 33 Reversing light switch (not Automatic)
- 34 Connection for reversing light switch
- 35 Wiper motor
- 36 Fusebox
- 37 Plug-in connection I
- 38 Load shedding relay
- 39 Earth (ground)
- 40 Plug-in connection II
- 41 Control unit for interval wiper operation
- 42 Hazard warning flasher contact
- 43 Screenwasher pump
- 44 Heater blower motor
- 45 Heater plug-in connection
- 46 Heater control
- 47 Earth (ground)
- 48 Glove box light
- 49 Glove box light contact
- 50 Connection for radio
- 51 Hazard warning flasher switch

- 52 Switch for heated rear window
- 53 Wiper speed control switch
- 54 Plug-in connector
- 55 Scale illumination
- 56 Switch for turning indicator, parking lights, wiper/washer operation
- 57 Plug-in connection for turning indicator switch
- 58 Plug-in connection for parking lights
- 59 Plug-in connection for low beam headlight switch
- 60 Low beam switch
- 61 Horn push
- 62 Ignition/starter switch
I = Halt; II = «0»; III = Fahrt (Drive); IV = Start
- 63 Main light switch
- 64 Switch for rear fog warning light and fog lights
- 65 Illumination contact
- 66 Plug-in connection for combined instrument
- 67 Clock
 - l) Dial illumination
- 68 Revolution counter
 - h) Brake telltale (handbrake)
 - l) Dial illumination
- 69 Speedometer
 - g) Turn indicator telltale (green)
 - l) Dial illumination
- 70 Combined instrument
 - a) Battery charge telltale (red)
 - b) Oil pressure telltale (orange)
 - c) Fuel gauge
 - d) Fuel level telltale (white)
 - e) High beam telltale (blue)
 - f) Coolant thermometer
 - l) Dial illumination

- | | |
|--|---|
| 71 Solder tag | 92 Transmission switch (Automatic only) |
| 72 Automatic transmission selector lever position indicating lights (Automatic only) | 93 Plug-in connection for transmission switch (Automatic only) |
| a) 1 (green) | 94 Plug-in connection for automatic transmission selector lever position indicating lights (Automatic only) |
| b) 2 (green) | 95 Voltage splitter for automatic transmission selector lever position indicating lights (Automatic only) |
| c) A (green) | 96 Contact for steel sliding roof (opt.) |
| d) O (white) | 97 Contact for automatically operated aerial (opt.) |
| e) R (red) | 98 Contact for trailer turning indicators (opt.) |
| f) P (white) | 99 Contact for fog lights (opt.) |
| 73 Handbrake telltale contact | 100 Contact for electrical fuel pump (opt.) |
| 74 Door-operated switch, right | 101 Window lift motor, front right (opt.) |
| 75 Door-operated switch, left | 102 Terminal connection (opt.) |
| 76 Stop light switch | 103 Plug board |
| 77 Luggage compartment light | 104 Switch 3 for window lift motor (opt.) |
| 78 Switch for luggage compartment light | 105 Switch 6 for window lift motor (opt.) |
| 79 Interior light | 106 Terminal connection |
| 80 Connection for rear loudspeaker | 107 Window lift motor, rear right |
| 81 Heated rear window | 108 Switch 4 for window lift motor |
| 82 Fuel gauge tank contact | 109 Switch 1 for window lift motor (opt.) |
| 83 Rear light cluster, right | 110 Window lift motor, front left (opt.) |
| a) Turn indicator | 111 Terminal connection (opt.) |
| b) Rear light | 112 Plug board |
| c) Stop light | 113 Switch 5 for window lift motor |
| d) Reversing light | 114 Switch 2 for window lift motor |
| 84 Earth (ground) | 115 Terminal connection |
| 85 Number plate light, right | 116 Window lift motor, rear left |
| 86 Number plate light, left | 117 Relay |
| 87 Connection for side marker light | 118 Temperature contact |
| 88 Rear fog warning light | |
| 89 Rear light cluster, left | |
| a) Turn indicator | |
| b) Rear light | |
| c) Stop light | |
| d) Reversing light | |
| 90 Plug-in connection for starter relay (Automatic only) | |
| 91 Starter relay (Automatic only) | |

opt. = optional

Electrical wiring diagram BMW 3.0 CS/A

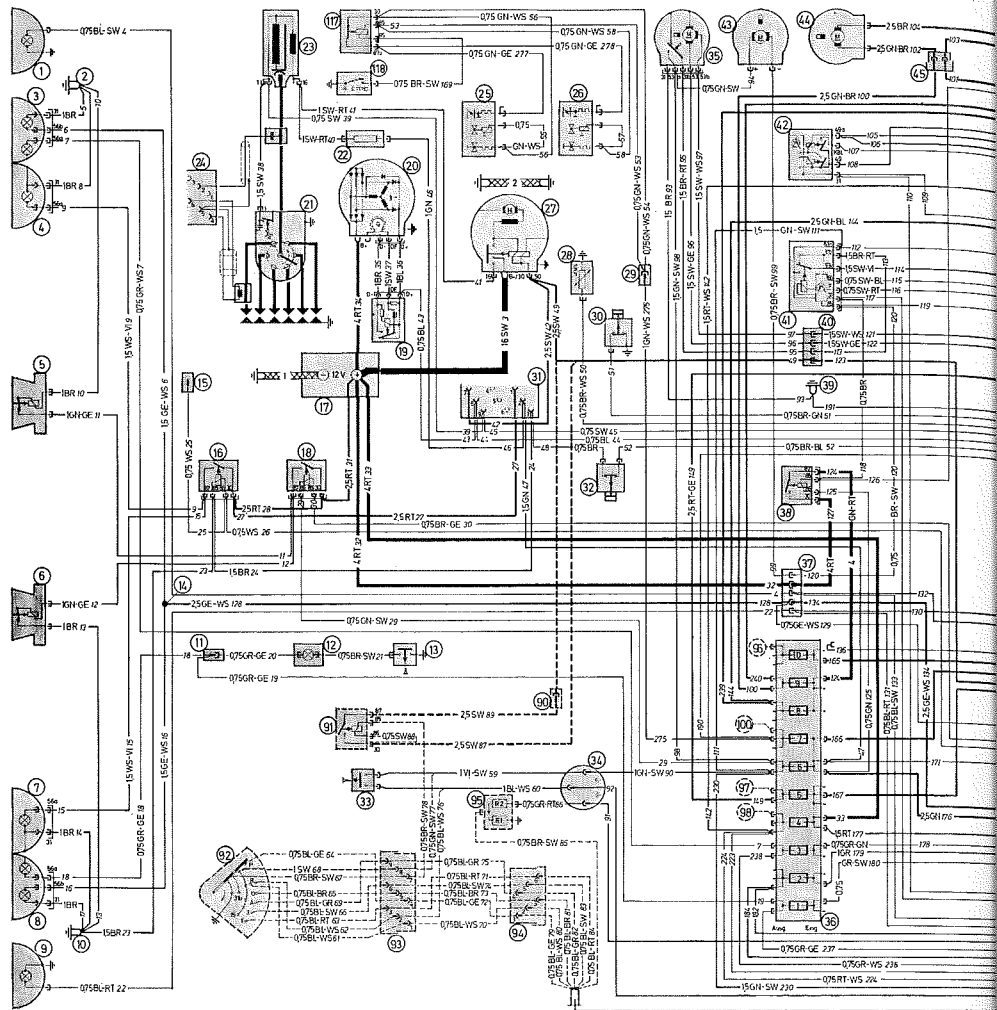

Key to electrical wiring diagram BMW 3.0 CSI

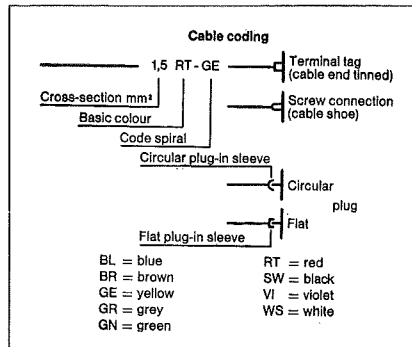

- 157 Injection valves cylinders 1–6
- 158 Temperature sensor – water
- 159 Starter valve
- 160 Temperature switch – water
- 161 Throttle butterfly switch
- 162 Main relay
- 163 Pressure sensor
- 164 Release
- 165 Fuel pump relay
- 166 Earth (ground)
- 167 Fuel pump
- 168 Plug-in connection Kl. 50
- 169 Cold start relay

- 17 Battery, 12 Volts
- 22 Primary resistance
- 23 Coil
- 27 Starter
- 36 Fusebox
- 62 Ignition/starter switch

100 Contact for electrical fuel pump

Wiring diagram for the electronically controlled fuel injection system

- 151 Electronic control unit
- 152 Multiple plug
- 153 Temperature sensor – air
- 154 Solder tag
- 155 Solder tag
- 156 Earth (ground)

Wiring diagram for the electronically controlled fuel injection system BMW 3.0 CSi/A

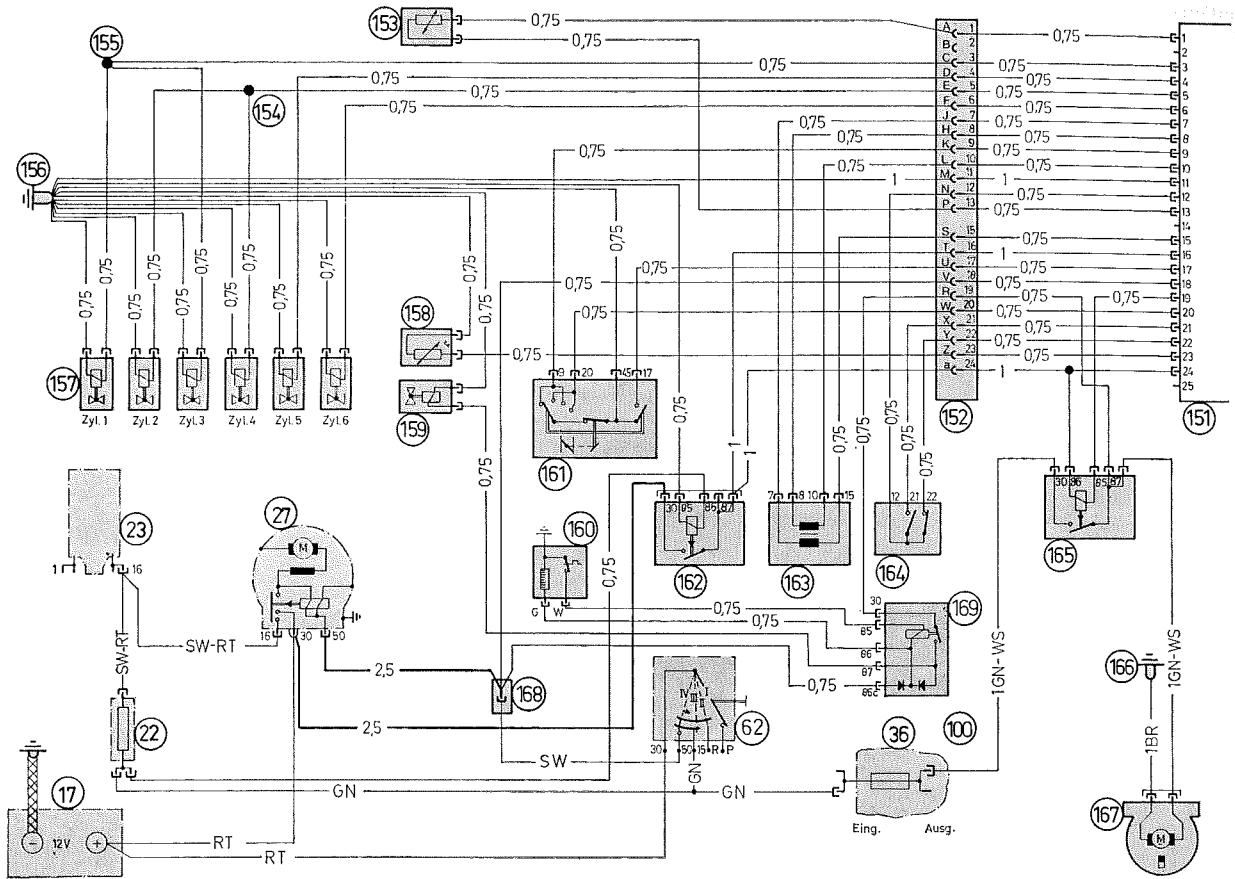

Approved oil grades for automatic transmission

Initial or subsequent filling

Esso	Esso Glide
Shell	S 7995

Subsequent filling only

Alex Duckham & Co.	Duckham's Q Matic
Amoco (U.K.) Ltd.	Amoco ATF Type F
Antar	Transantar 33
Aral AG	Aral Gear oil ATF 33
Automatic Transmission Services	ATF
BP	Autran B
Castrol	Castrol TQF
Filtrate Limited	Filtrate Automatic Transmission Fluid F
Rudolfs Fuchs Mineralölwerk KG	Fuchs Automatic TF M2C—33F
Gulf Oil (GB) Ltd.	Gulf ATF Type F
Idemitsu Kosan Co. Ltd.	Apolloil Mission F
Mitsubishi Oil Co.	Diamond ATF Special F
Mobil Oil Co.	Mobil ATF 210
Petrofina (U.K.) Ltd.	Fina Purifimatic 33 F
Regent/Texaco/Caltrex	Texamatic 6991 Type F
Shell	Donax T 7
Sun Oil Co.	Sunamatic 126
Tiona Petroleum Co.	Flo-Matic ATF Type F
Total	Total ATF 33
Valvoline Oil Co.	Valvomatic ATF Type FA
Veedol	Veedol ATF F

Approved oil grades for hydraulic power steering**Initial or subsequent filling**

AGIP F 1 ATF Dexron B 11297
 BP Aufran B
 BP Aufran DX B 11026
 Castrol TQ Dexron B 10476
 Esso gear oil DB
 Esso Glide ATF Type F
 ESSO ATF Dexron B 10696
 Mobil Transmission Oil DB
 Mobil ATF 220 B 10467
 Mobil ATF 220 B 10569
 Ritzol gear oil
 Shell Donax T 7
 Shell oil Dexron B 10378
 Texaco Texamatic Fluid 6673 (E) B 10334
 Texaco Texamatic Fluid 6991 Code 1865
 Texaco Transmission Oil DB
 Veedol ATF Spezial 3433

Subsequent filling only

Aral ATF 33
 Aral Getriebeöl SGF AQ 1841 A
 ATF Dexron B 11499
 Avia Fluid ATF 66 M (Type A Suffix A) AQ 3028 A
 BP ATF Type A Suffix A AQ-ATF 3028 A
 Caltex Texamatic Fluid AQ 1800 A
 Castrol TQ AQ 737 A
 Chevron ATF Type A 68
 Deutz Oel HY-F AQ 2415 A
 Esso Automatic Transmission Fluid AQ 2974 A
 Fuchs Automatic TF 10
 Gasolin Special Getriebeöl Fluid AQ 1842 A
 Gulf ATE Type Suffix A AQ 1200 A
 Mobil ATF 200 AQ 752 A
 Quaker State Quadromatic ATF Type A
 Shell Donax T 6 AQ 2415 A
 Sunoco Automatic Transmission Fluid AQ-ATF 737 A
 Total Fluid A, AQ 1577 A
 Valvoline Valvomatic Transmission Fluid Type A-TQ 7 A
 Veedol Automatic Transmission Fluid Type A, Suffix A 1407 A

Agip AG, Munich
 BP-Benzin and Petroleum AG, Munich
 BP-Benzin and Petroleum AG, Munich
 Deutsche Castrol GmbH, Hamburg
 Esso AG, Hamburg
 Esso AG, Hamburg
 Esso AG, Hamburg
 Mobil Oil AG, Hamburg
 Mobil Oil AG, Hamburg
 Mobil Oil AG, Hamburg
 Valvoline Oel GmbH, Ritz u. Co., Hamburg
 Deutsche Shell AG, Hamburg
 Deutsche Shell AG, Hamburg
 Texaco Inc., New York (USA)
 Texaco Inc., New York (USA)
 Texaco Inc., New York (USA)
 Getty Oil GmbH, Hamburg

Viscobil Fluid AQ 156/326/349/602
 Aral AG, Bochum
 Deutsche Avia Mineralöl GmbH, Munich
 BP-Benzin and Petroleum AG, Munich
 Caltex Petroleum Corp., New York
 Deutsche Castrol GmbH, Hamburg
 Chevron Erdöl Deutschland GmbH, Frankfurt
 Deutzer Öl GmbH, Köln
 Esso AG, Hamburg
 R. Fuchs, Mineralölwerk KG, Mannheim
 Gasolin AG, Hannover
 Gulf Oil Deutschland GmbH, Hamburg
 Mobil Oil AG, Hamburg
 Quaker State Oil, Oil City/Pa (USA)
 Deutsche Shell AG, Hamburg
 Sun Oil Company, Antwerpen (Belgien)
 Deutsche Total GmbH, Düsseldorf
 Valvoline Oel GmbH, Ritz & Co., Hamburg
 Getty Oil GmbH, Hamburg
 DEA und Texaco GmbH, Hamburg

Service all the way

Superior engineering is worthy of your confidence. You will certainly have noticed that after having driven just a few miles in your new BMW.

Naturally, a quality car like yours should be serviced and cared for in the correct way, so that your sheer driving pleasure will remain just as great for years to come.

When having your car serviced or when a repair is to be done, please make sure that this carried out by an authorized BMW service station only. BMW service stations have all the equipment and tools that are specially designed for your car, and they are obliged by contract to use only ORIGINAL BMW PARTS for your BMW.

It pays off to be careful when somebody offers you spares "that are just as good as the original ones". As we are unable to examine these parts for quality, we cannot assume any warranty if they are used. And it might even lead to legal difficulties if your BMW is fitted with non-BMW spares.

Thanks to ORIGINAL BMW PARTS, you can always protect yourself against any such trouble and need not run a risk. ORIGINAL BMW PARTS are not like normal spares. They are completely identical with the original parts used in a new BMW. So that "replacing an original part by another original part" gives you the same technical superiority that

is so characteristic of BMW. Needless to say, this is essential for maintaining the supreme power and safety reserves of your car.

Original BMW Parts and Replacement Parts are all supplied by BMW, irrespective of whether they are manufactured by BMW or other firms (suppliers).

Every BMW dealer has concluded a contract with the factory, stipulating that he must always keep a stock of the following ORIGINAL BMW PARTS:

- spare parts and replacement parts required frequently
- ORIGINAL BMW ACCESSORIES

This means that your BMW service station will usually be able to help you right away whenever necessary.

ORIGINAL BMW PARTS needed only rarely — after all, there are about 29,000 parts altogether — can be obtained very quickly by small dealers from the nearest distributor or BMW branch.

**Original
BMW Teile**



Look for this sign

Your BMW Dealer has them . . . accessories for even greater sheer driving pleasure

Original BMW trailer bracket

For your caravan or boat trailer. Offers absolute road safety. Also available with detachable ball head.

BMW car radio (stereo available)

High-quality BECKER, BLAUPUNKT and PHILIPS car radios — that fulfil the standards for Original BMW Accessories — give you a perfect sound when built into your car with original BMW installation kits, suppression equipment and aerials.

Original BMW interior carpets

Choose what you prefer: rugged fibre floor mats or extrafine velours carpets. And choose the colour you like. All BMW interior carpets have some features in common: they are sporty, attractive, fit in exactly and will not slip.

Original BMW first-aid cushion

In Germany and most other countries the traffic code states that a first-aid kit must be carried in all cars. The attractive and rugged BMW first-aid cushion is even nice to have if it not used for first-aid. Bears the BMW emblem.

Original BMW rubber floor mats

Just the right thing for the wet season. Available in anthracite with the BMW emblem.

Original BMW quartz-iodine fog lamp

Either round or rectangular in shape, also available together with a rear fog warning light to match. Ready to be attached to your car.

Original BMW reserve pack of service parts

Containing a number of parts particularly for the electrical system of your BMW: Fuses, spark plugs, bulbs, distributor, distributor rotor, as well as filters, V-belts and gaskets. All packed in a compact flat box.

Original BMW gear shift lever head

Gives you just the right grip for superior motoring. Beautifully finished in wood or rear leather with the BMW emblem.

Original BMW mudguards

In some countries (e. g. Yugoslavia) mudguards are mandatory on all cars. The fair BMW motorist uses mudguards as a token of politeness to other drivers and to keep his own car cleaner.

Original BMW safety belts

We recommend 3-point safety belts for the front seats. Many BMW drivers choose the sporty BMW/Klippan safety belts that are anchored to the propshaft tunnel and can be fastened or removed with one hand.

Original BMW safety steering wheel

Gives you the right feeling for the road beneath and is pleasant to hold. Ideal for fast maneuvering. Bears the BMW emblem.

Original BMW wind deflector

Avoids unpleasant draughts in the car when the sliding roof is opened.

Further Original BMW Accessories

Paint spray aerosols and touch-up sticks, fuel filler cap with lock, protection grilles for stone-throw, covers for additional headlights with emblem, protective strip for door sill, chrome exhaust tip, ornamental wheel caps, warning triangle, torch with cable, BMW/Talbot sports rear-view mirror.

Original BMW perfection to the very last detail . . . for accessories too

Item reference

- Acceleration 95, 96
Adjusting handbrake 75
Adjusting headlights 51–53
Air extraction 25
Air filter elements 71, 73, 84
Alternator 74, 92
Antifreeze 41, 66
Artificial leather 55
Ashtray 22
Automatic choke carburettor 76
Automatic screenwasher 11, 12
Automatic transmission 26, 27, 85
Axle load 93
- Battery 65, 66, 92, 100–105
Battery acid level 65
Battery charge telltale 15, 49, 100–105
Blower 24, 90, 91
Blower switch 24
BMW Program Test 58–60, 64–74, 99
BMW Spare Parts Service 108, 109
Bodywork, care of 54, 55
Brake fluid 64, 98, 99
Brake fluid change 64, 98, 99
Brakes 75, 88–90
Bulb-changing 49–51
- Carburettors 76, 84
Carburettors, adjustment of 76
Car jack 43
Car radio 22
Changing of bulbs 49–51
Chassis number 6
Checking oil level 38, 61–63, 98, 99
Chromium, care of 55
Chromium preservatives 55
Cigar lighter 8, 9, 20, 100–105
Clock 8, 9, 20
Clutch 64, 65, 85
- Clutch travel 64
Coil 92
Combined instrument 15, 16, 49
Compression ratio 81, 82
Contact breaker points gap 70, 92, 113
Continuous engine speeds 35, 81, 82
Controls and instruments 8, 9
Coolant thermometer 16
Coolant thermostat 84
Cooling fan 84
Cooling system 66, 67, 84
Cooling system, capacity of 41, 113
Cooling system, filling of 66, 67
Cooling system plug 67, 84
Crankshaft 80
Cubic capacity 81, 82
Cylinder block 80
Cylinder head 58, 59, 72, 80, 97
Cylinder head studs, tightening of 58, 59, 72, 97
- Diagnostic plug 100–105
Dimensions 93
Dipped beam 8, 9, 10, 49, 50, 92, 100–105
Dipped beam switch 8, 9, 10, 100–105
Dipstick 38, 62
Distributor 64, 70, 92
Distributor, lubrication of 64
Distributor release contacts 71
Door locks 7
Driving hints 36, 38, 39
Dwell angle 70, 92
- Economy 36
Electrical fuel pump 84
Electrical system 92, 93, 100–105
Electrical wiring diagrams 100–105
Electronic fuel injection system 29–33
Engine compartment lid 12

Engine compartment lock 12
 Engine number 6
 Engine oil change 61
 Engine oil consumption 38, 84
 Engine speed-road speed diagram 83, 85

Filling capacities 113
 Final drive, oil change 63, 98, 99
 Final drive ratio 86
 Firing order 72, 92
 Flasher 8, 9, 10, 100–105
 Fog lamps (optional) and rear fog light 13, 17
 Foreign travel 39
 Fresh air grille 24, 25, 90, 91
 Front panel protection 62
 Front seats, adjustment of 17, 18
 Front track 87
 Front wheel suspension 86, 87
 Fuel 36
 Fuel consumption 36
 Fuel filler 16
 Fuel filters 68, 69, 84
 Fuel gauge 16
 Fuel injection system 29–33
 Fuel pump 68, 84
 Fuel reserve 16
 Fuel tank capacity 113
 Fuses 48

Gearbox 85
 Gearbox, filling capacity 62, 113
 Gearbox gate pattern 19
 Gearbox, oil change 62, 98, 99
 Gearbox, oil grades 62, 98, 99, 113
 Gear ratios 85
 Glove box 8, 9, 20
 Gradients, maximum 95, 96
 Ground clearance 93

Handbrake 75, 89
 Handbrake, adjusting of 75, 89
 Hazard warning flashers 8, 9, 14, 48, 100–105
 Headlight 8, 9, 10, 49, 52, 53
 Headlight switch 8, 9, 10
 Heating 24, 25, 90, 91
 High-beam headlight 8, 9, 10, 50, 52, 92, 100–105
 High-beam headlight telltale 8, 9, 15
 Horn 15, 93, 100–105
 Horn push 8, 9, 15
 Hydraulic power steering 39, 40, 63, 88, 98, 99, 113

Ignition advance 92
 Ignition coil 92
 Ignition/starter switch 8, 9, 10, 100–105
 Ignition timing 70, 92, 113
 Ignition timing mark 70, 92, 113
 Instrument lighting 10, 49
 Intake air preheat 73
 Intake air silencer 67, 68, 71
 Interior dimensions of body 94
 Interior light 19
 Interior rear view mirror 19
 Internally-vented brake discs 88
 Interval wiper operation 11

Keys 6, 7
 Kingpin inclination 87

Length 93
 Licence plate light 51, 100–105
 Lifting points for car hoist 98
 Limited-slip differential 40
 Locks 6, 7
 Low-beam headlight 8, 9, 10, 49, 50, 92, 100–105

Low-beam switch 8, 9, 10, 100–105
 Lubrication 63, 64, 98, 99
 Lubrication chart 98, 99
 Luggage compartment lid 7
 Luggage compartment light 17, 51
 Luggage compartment lock 7

Maintenance 54–77
 Maintenance routines, description of 61–75
 Maker's plate 6
 Maximum engine speed, permissible 34, 35, 81
 Maximum road speed, permissible 35, 95, 96

Number plate light 51, 100–105

Octane rating 36
 Oil additives 38
 Oil consumption 38, 81
 Oil dipstick 38, 62
 Oil filler for engine 98
 Oil filter 62
 Oil grades 38, 61, 62, 63, 98, 113
 Oil level, checking of 38, 61–63, 98, 99
 Oil pressure telltale 8, 9, 15, 49
 One-season underseal 42
 Output 81, 82
 Output diagram 81, 82
 Overhang 93

Paintwork, care of 55
 Parking 26
 Parking lights 11, 100–105
 Pistons 80
 Power steering 39, 40, 63, 88
 Preservation of underfloor 41, 55
 Propeller shaft 85

- Radial-ply tyres 41, 88, 113
- Rear lights 17, 50, 100–105
- Rebalancing of wheels 65
- Release contacts — distributor 71
- Reversing light 19
- Road speed — engine speed 83, 85
- Roof load 93
- Rubber parts 41, 55
- Running in rules 34, 35
- Running in the brakes 35

- Safety belts 18
- Seat adjustment 17, 18
- Service 58–60
- Service booklet 56
- Side light 10, 49, 50, 100–105
- Small stowage compartment 8, 9, 12
- Snow chains 41
- Socket 20
- Spare wheel 43
- Spark plug electrode gap 69, 92, 113
- Spark plugs 69, 92, 113
- Spark plugs, changing of 69
- Special coating of cavities 42
- Specifications 80–97
- Speedometer 8, 9
- Stains 55
- Standard fuel consumption 36
- Starter 92
- Starting the engine 28
- Steering 39, 40, 63, 88, 98, 99, 113
- Steering lock 10
- Steering mechanism, oil change 39, 40, 63, 88, 98, 99, 113
- Stop light 17, 50, 100–105
- Stopping distance 89
- Stopping the engine 29

- Tar stains 55

- Technical modifications 39
- Thermostat 84
- Tightening torques 97
- Toe-out on turns 87
- Toolkit 44
- Torque diagram 81, 82
- Towing away 27, 44, 46
- Towing eyes 44, 46
- Towing with automatic transmission 27
- Track circle 93
- Track (of wheels) 93
- Track rods 88
- Trailer load 93
- Trip mileage recorder 8, 9, 13
- Turn indicator lever 8, 9, 11
- Turn indicator lights 8, 9, 11
- Turn indicator telltale 8, 9, 11, 49
- Turning circle 93
- Twin dual-circuit brakes 38, 88
- Tyre dimensions, changing of 39
- Tyre pressures 113
- Tyres 88, 115

- Underfloor protection 42, 55

- Valve clearance 72, 83, 113
- Valves 72, 83, 113
- Valve timing for test purposes 83
- Valve timing test periods 83
- V-belt 74, 113
- Ventilation 8, 9, 24, 25, 91
- Voltage regulator 92

- Washing the car 54
- Wheelbase 93
- Wheel bearings, lubrication of 63, 98, 99
- Wheel camber 87
- Wheel lock 87
- Wheel rims 88

- Wheels, interchanging of 65
- Wheels, rebalancing of 65
- Width 93
- Winter precautions 41, 42
- Winter tyres 41, 113
- Wiper arms 46
- Wiper blades 46
- Wiper speed preselector switch 11
- Wiper switch 8, 9, 11
- Wiring diagrams 100–105

At a glance*)

Tyre pressures in lbs/sq. in (atm) for cold radial ply tyres. (For warm radial ply tyres, add 4 lbs/sq. in (0.3 atm) more):

195/70 VR 14

Load	front	rear
up to 2 persons	28 (2.0)	28 (2.0)
4 persons plus luggage	31 (2.2)	31 (2.2)

These pressures need not be increased for winter and studded tyres, 195/70 SR or HR, 175 SR or HR 14.

Spark plugs

Beru 175/14/3 A
Bosch W 175 T 30
Champion N 9 Y
Special equipment:
Bosch WG 175 T 30
or
Beru G 175/14/3
(air surface gap spark plugs)

Electrode gap: 0.024+0.004"
(0.6+0.1 mm)

Contact breaker points gap

0.014–0.016" (0.35–0.40 mm)
Dwell angle 35°–41° (BMW 3.0 CS)
or 39°–45° (BMW 3.0 CSI)

Ignition timing

22° BTDC (marking) at 1700 rpm for the BMW 3.0 CS and 2500 rpm for the BMW 3.0 CSI

Valve clearances with engine cold:

Inlet and exhaust 0.01–0.012"
(0.25–0.30 mm)

V-belts

12.5 x 1050 serrated (narrow V)
9.5 x 1075 DIN 7753
(for drive to high-pressure vane type pump).

Capacities

Fuel tank	15.4 gal. (Imp.)/18.5 gal.(US)/70 litres	Super (premium) grade fuel
Cooling system including heater	21.1 pints (Imp.)/12.7 quarts (US)/12 litres	For details, see page 41
Engine oil	8.8 pints (Imp.)/10.6 pints (US)/ 5 litres, plus 1.3 pints (Imp.)/1.6 pints (US)/ 0.75 litres if filter is changed	Branded 4-stroke HD oil For oil grades, see page 61
Gearbox (manual)	Approx. 1.9 pints (Imp.)/2.3 pints (US)/ 1.1 litres	Branded gearbox oil, SAE 80 (in an emergency, use engine oil, see page 61)
Automatic transmission	Approx. 3.2 pints (Imp.)/3.8 pints (US)/ 1.8 litres; initial filling of new or exchange transmission 11.0 pints (Imp.)/13.2 pints (US)/6.25 litres; no change of oil required	For oil grades, see page 104
Final drive	2.6 pints (Imp.)/3.4 pints (US)/ 1.5 litres	Branded running-in grade hypoid gear oil, SAE 90 (your BMW service station can recommend factory approved oils)
Hydraulic power steering	2.1 pints (Imp.)/2.5 pints (US)/1.2 litres (Permanently filled, no drain plug)	For oil grades, see page 105

*) not applicable for US models

Bayerische Motoren Werke AG München

Best.-Nr. 01 41 9 599 421 e. 2. IV. 73 Printed in Western Germany au